

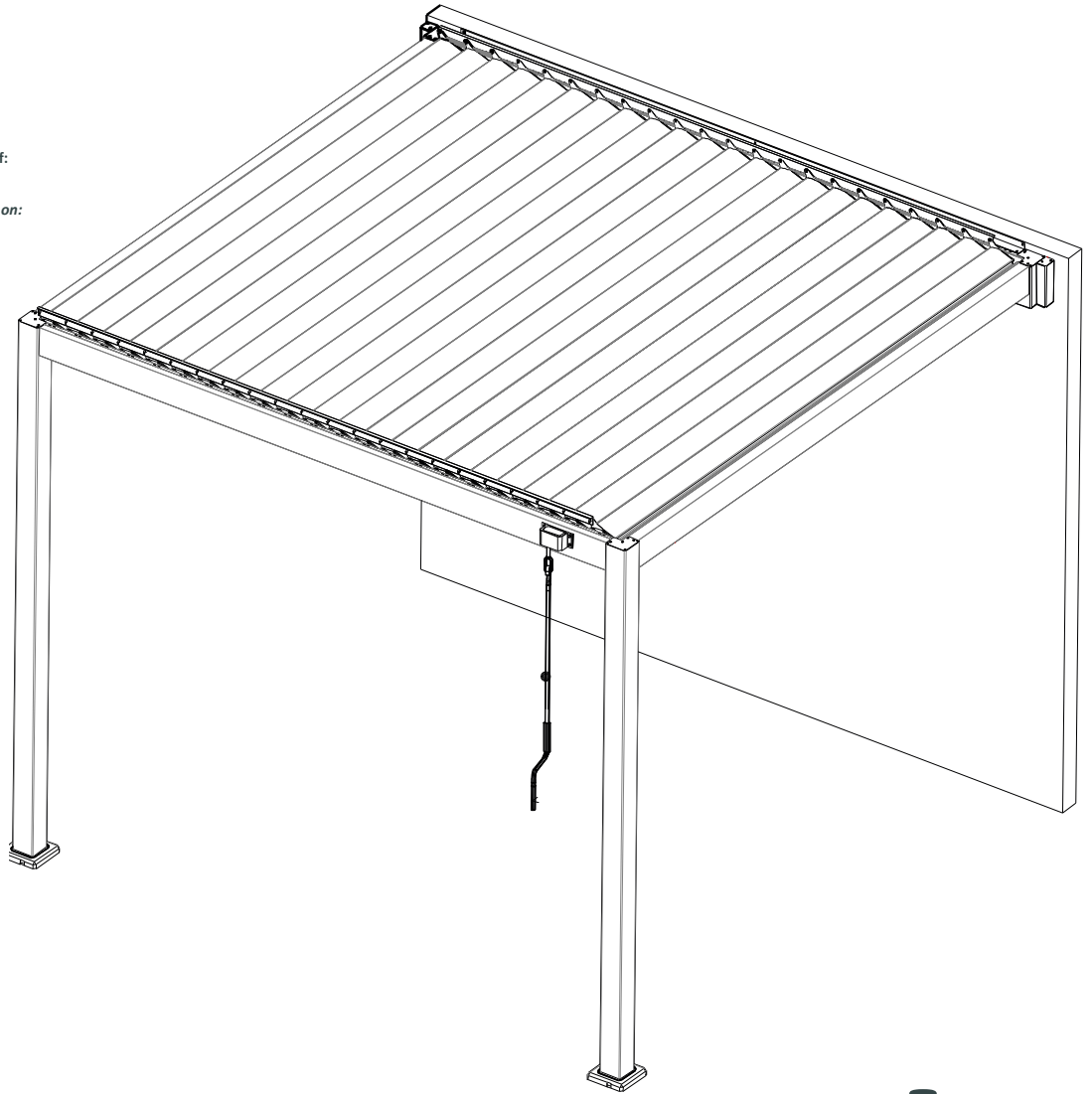

Eine aktuelle Version dieser Anleitung finden Sie auf:
<https://www.pergomondo.de/anleitungen/>

A current version of these instructions can be found on:
<https://www.pergomondo.de/anleitungen/>



pergomondo

Wandmontageset für Pergola mit Lamellendach
3x3 m / 3x4 m

Montageanleitung / installation instructions

DE

Sicherheitshinweise.....	3-4
Verpackungsinhalt	5
Montage.....	6-21
Leistungserklärung	22
Konformitätserklärung	23
Kontaktinformationen	letzte Seite

EN

<i>Safety instructions</i>	25-26
<i>Package content</i>	27
<i>Installation</i>	28-43
<i>Notes</i>	44-45
<i>Declaration of performance</i>	46
<i>Declaration of conformity</i>	47
<i>Contact information</i>	<i>last page</i>

Lesen der Montage- und Bedienungsanleitungen

Die Montage- und Bedienungsanleitung (im Folgenden auch Handbuch genannt) muss vor der Montage gelesen und beachtet werden.

Eine Nichtbeachtung der Montage- und Bedienungsanleitung entbindet den Hersteller von seiner Haftungspflicht.

Dieses Handbuch wurde als Grundlage für die Montage, Installation und Wartung des auf Seite 1 aufgeführten Produktes erstellt.

Änderungen am Inhalt des Handbuches oder Modifikationen der Seiten sind untersagt.

Der Hersteller behält sich jederzeit das Recht vor, Änderungen am Produkt und am Inhalt dieser Anleitung, ohne vorherige Ankündigung, vorzunehmen.

Das Handbuch ist vollständig an einem jederzeit leicht zugänglichen Ort aufzubewahren und muss bei einer eventuellen Übertragung des Produktes an Dritte an den neuen Besitzer weitergegeben werden.

Warnsymbole

Sicherheitshinweise und wichtige Informationen sind an entsprechender Stelle zu finden und mit einem Symbol versehen.



Dieses Symbol kennzeichnet Hinweise, die für die Sicherheit von Personen oder für die Funktion des Produktes wichtig sind.



Dieses Symbol kennzeichnet wichtige Produktinformationen für den Monteur oder Nutzer.



Dieses Symbol kennzeichnet Hinweise auf besondere Gefahren für Personen und/oder des Produktes und deren Zubehör. Nichtbeachtung kann, z.B. durch Stromschlag, zu schweren Verletzungen, oder zum Tod führen.

Montagehinweise

Für die Montage der Pergola in der Größe 3x3 m sind mindestens 3 Personen und bei der Variante 3x4 m mindestens 4 Personen erforderlich.

Wir empfehlen eine maximale Hebelast von 15 kg/weibliche Person bzw. 25 kg/männliche Person.

**Lagerung**

Die Verpackung des Produkts ist vor Nässe zu schützen. Eine aufgeweichte Verpackung kann sich lösen und zu Unfällen führen.

Bei Lagerung muss das Produkt dauerhaft vor Nässe und eindringender Feuchtigkeit geschützt werden! Stapel sind so zu errichten und abzutragen oder abzubauen, dass Personen nicht durch herabfallende, umfallende oder wegrollende Gegenstände gefährdet werden.

**Montage**

Um eine ordnungsgemäße Montage und damit eine optimale Funktion des fertigen Produkts zu gewährleisten, sind folgende Geräte erforderlich:

- Akkuschauber
- Komplettes Werkzeugset
- Handschuhe
- Silikon
- Ausrüstungen für Höhenarbeiten (Gerüste, Leitern, Hubarbeitsbühnen usw.), die den aktuellen Standards für die individuelle Sicherheit am Arbeitsplatz entsprechen

Achten Sie auf ein gleichmäßiges Anziehen aller Schrauben. Ein ungleichmäßiges Anziehen kann zu Verspannungen in den Aluminium- und Gussteilen zum Versagen der Befestigung führen. Die Montage muss in Übereinstimmung mit den geltenden Richtlinien und Standards zur Arbeitssicherheit durchgeführt werden.

Prüfen Sie vor dem Gebrauch alle Arbeitsmittel (Gerüste, Leitern, Werkzeuge etc.). Verwenden Sie immer eine geeignete Schutzausrüstung (Handschuhe, Sicherheitsschuhe, Schutzbrille, Gehörschutz etc.).

Wenn mehrere Personen an der Anlage arbeiten, müssen deren Arbeiten koordiniert werden.

Wandmontage

Die Auswahl des am besten geeigneten Befestigungselements hängt von der Art der Wand und ihrem physikalischen Zustand ab. Bitte prüfen Sie vor der Installation der Pergola, den Zustand der Wand. Das Befestigungsmaterial für die Wandmontage ist nicht im Lieferumfang enthalten.

Prüfen Sie vor der Montage den Inhalt Ihres Lieferumfanges. Montieren Sie das Produkt nicht, wenn Sie beschädigte oder fehlende Teile bemerken. In diesem Fall kontaktieren Sie bitte unseren Kundenservice, der sich umgehend um Ihr Anliegen kümmern wird.

Die Pergola muss durch die im Lieferumfang enthaltenen Betonanker am Boden befestigt werden.

**Befestigungsmaterial**

Die Lieferung des Wandmontagesets erfolgt ohne Befestigungsmaterial!

Das Befestigungsmaterial muss vom Monteur für den vorhandenen Montageuntergrund ausgewählt und nach den Erfordernissen der Anlage und des Montageuntergrundes abgestimmt werden.

Hierbei sind die Angaben zu den erforderlichen Dübelauszugskräften zwingend einzuhalten. Wir übernehmen keine Haftung für das Befestigungsmaterial. Allein der Monteur haftet dafür, dass das Befestigungsmaterial für den jeweiligen Montageuntergrund geeignet ist und dass die Montage fachgerecht ausgeführt wird.

Die jeweiligen Montagehinweise der Dübel-Hersteller sind unbedingt zu beachten!

**Reinigungs- und Pflegehinweise**

Temperaturschwankungen und Luftfeuchtigkeit können zur Bildung von Kondenswasser an der Pergola und im Außenbereich führen, was nicht bedeutet, dass das Produkt undicht ist.

Überprüfen Sie regelmäßig, insbesondere im Herbst und Winter, die Stabilität Ihrer Pergola. Entfernen Sie Laub, Steine, Äste und andere Gegenstände von der Pergola. Sobald sich Schnee auf dem Dach ansammelt, muss dieser umgehend entfernt werden.

Bei witterungsbedingten Schäden wie Schnee oder Sturm bestehen keine Gewährleistungsansprüche. Verwenden Sie keine starken Reinigungsmittel wie z.B. Lösungsmittel oder korrosive Flüssigkeiten für die Reinigung Ihrer Pergola. Wischen Sie diese mit einem feuchten Tuch ab.





**Warnung**

Bewahren Sie Verpackungsmaterialien außerhalb der Reichweite von Kindern auf und entsorgen Sie diese sofort. Es besteht Erstickungsgefahr.



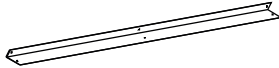







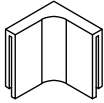

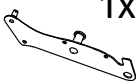

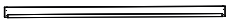
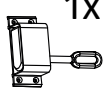

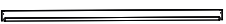

Sollte sich unerwartet herausstellen, dass Ihr Produkt defekt ist, oder Teile fehlen, kontaktieren Sie bitte unseren Kundenservice. Bitte halten Sie Auftragsnummer bereit.

Für weitere Fragen wie z.B. die vielfältigen Erweiterungsmöglichkeiten unserer Pergola steht Ihnen unser Team gerne zur Verfügung.

In diesem Wandmontageset enthalten:

K		4x	F		1x
Wandhalterung 1		1x	D		2x
Wandhalterung 2		1x			

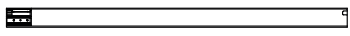
Diese Teile werden mit Ihrer Pergola geliefert und sind in dieser Anleitung nur zur Veranschaulichung der Montageschritte aufgeführt und abgebildet:

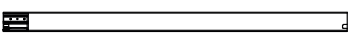
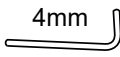
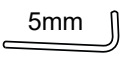
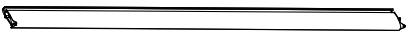
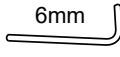
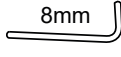
TB		1x	O		4x
BB		1x	G	 1x  ST4.2X20 3x  1x	
LB		1x	V	 1x  1x  1x  M6X25 4x	
RB		1x	B	 4x  ST4.2X25 20x	
Zugstange		2x	C		4x
Balkenabdeckung		2x	H	 ST4.2X16 (3x3m) 102x (3x4m) 130x	
Handkurbel		1x	R	 Ø1.5X28 (3x3m) 42x (3x4m) 62x	
Pfosten 1		2x	E	 M6X16 16x	
Pfosten 2		2x		 4mm 2x	 5mm 2x
Lamellen		(3x3m) 21x (3x4m) 29x		 6mm 1x	 8mm 1x

Pfosten 1

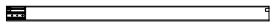

2x

B



2x

10x

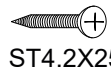

ST4.2X25

C

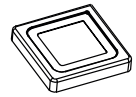

2x

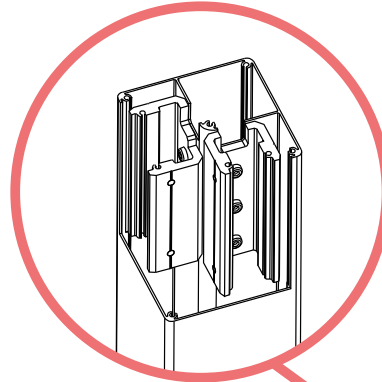

Pfosten 1

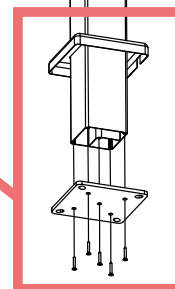
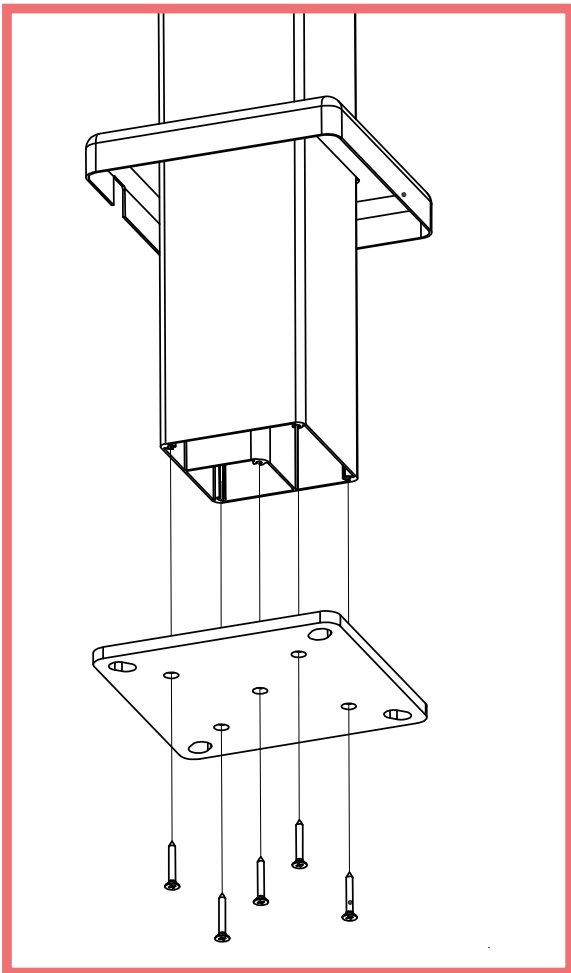
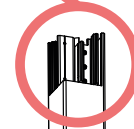

Pfosten 2

2x

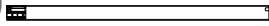

B



2x



10x

ST4.2X25

C

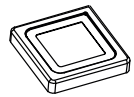

2x

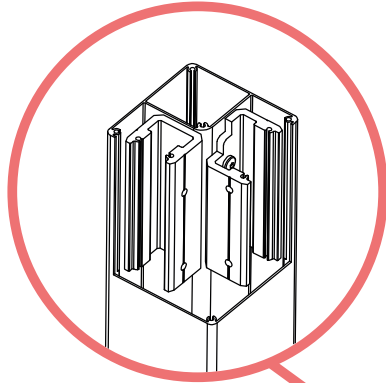

Pfosten 2

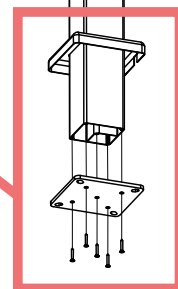
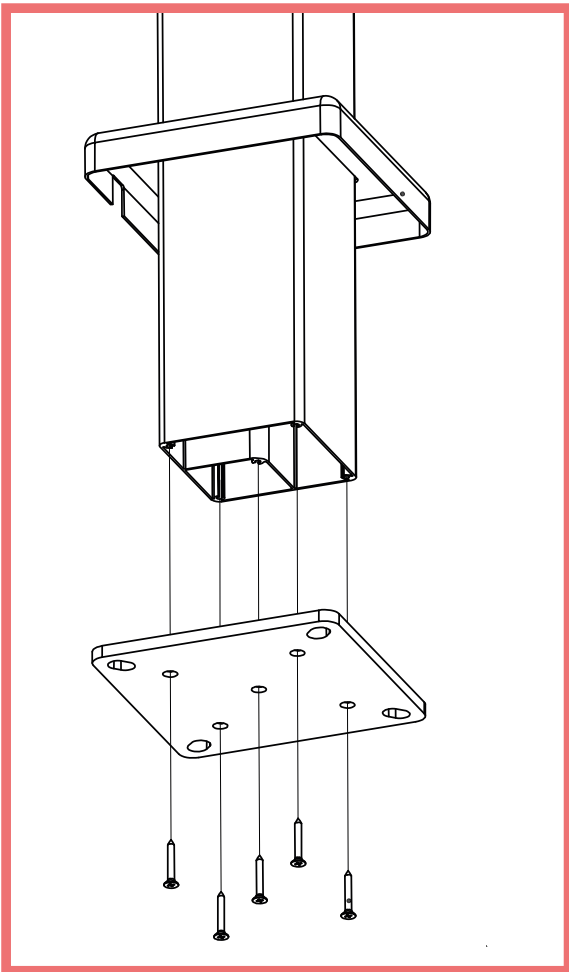
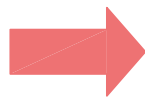
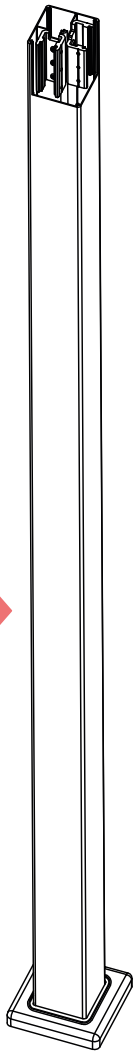
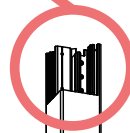

Wandhalterung 1



1x

Wandhalterung 2



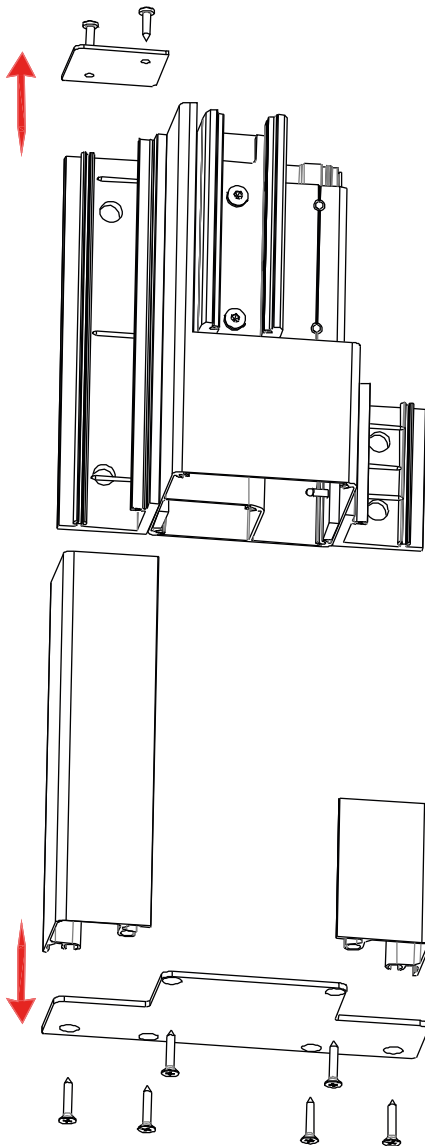

1x

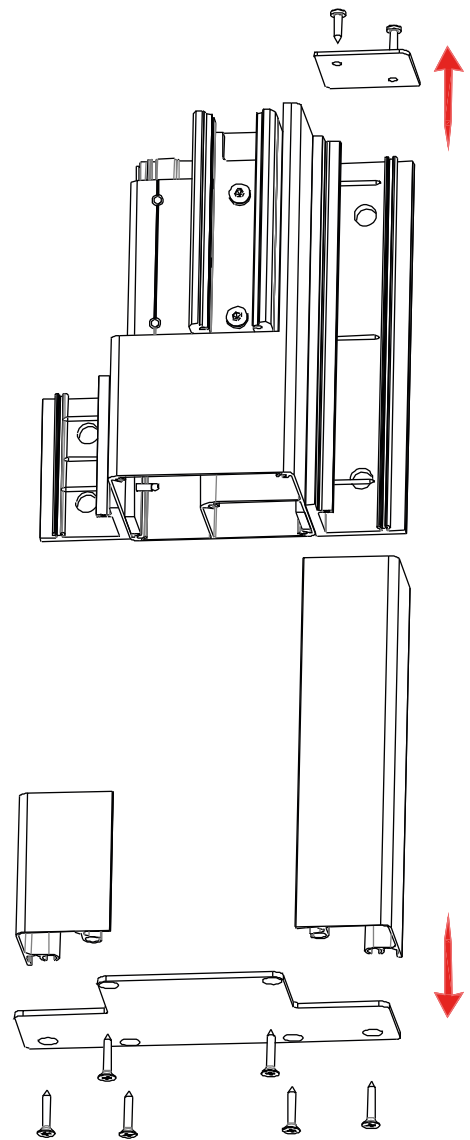

aufschrauben



TB  1x	E  M6X16 4x	H  ST4.2X16 2x
--	---	--

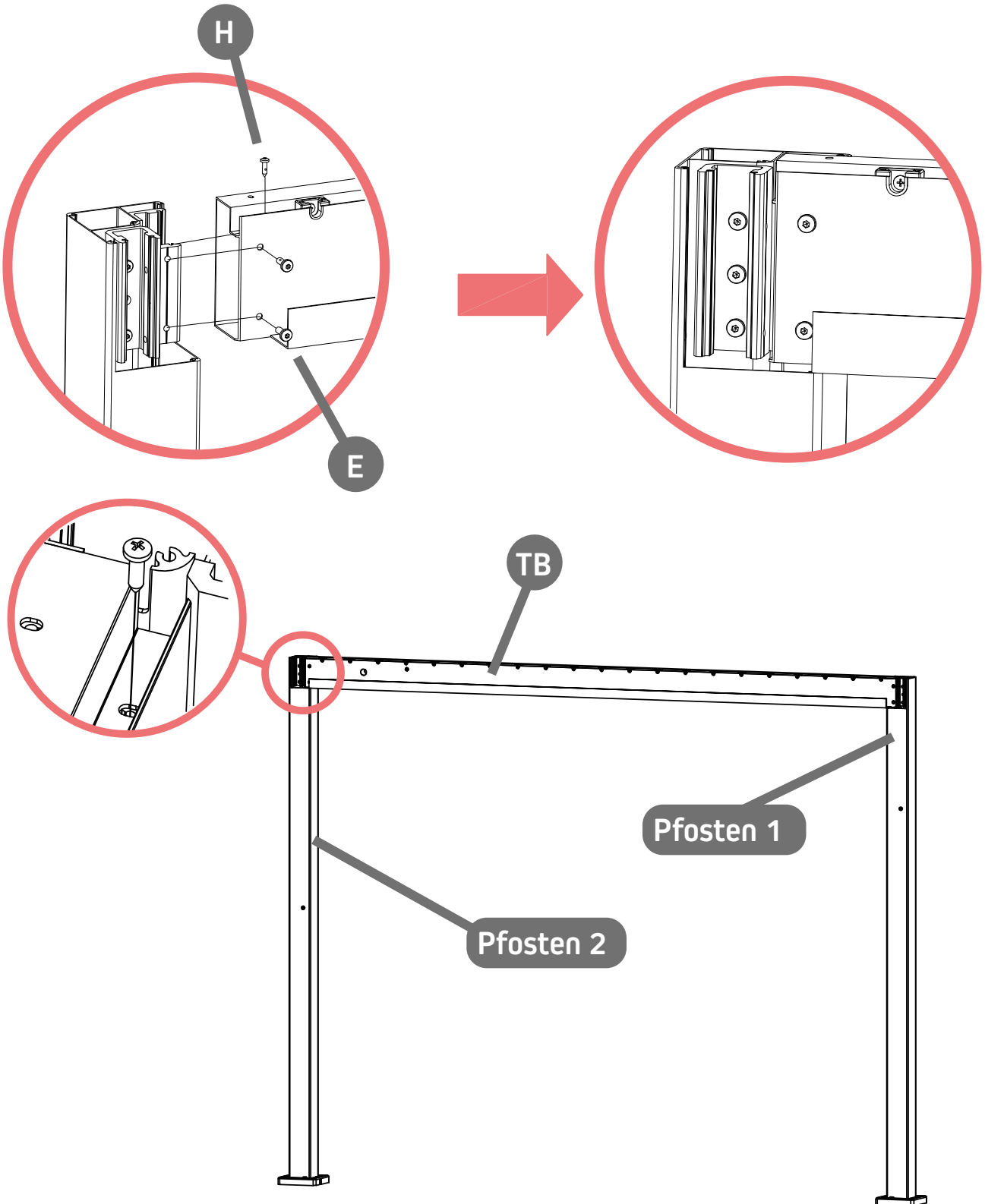

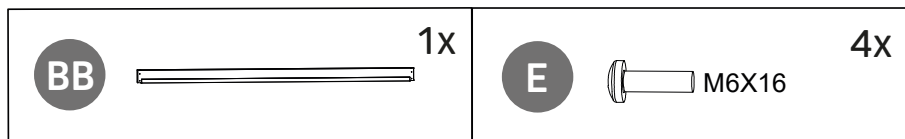

*)Das Befestigungsmaterial für die Wandmontage ist im Lieferumfang nicht enthalten (siehe S. 4)

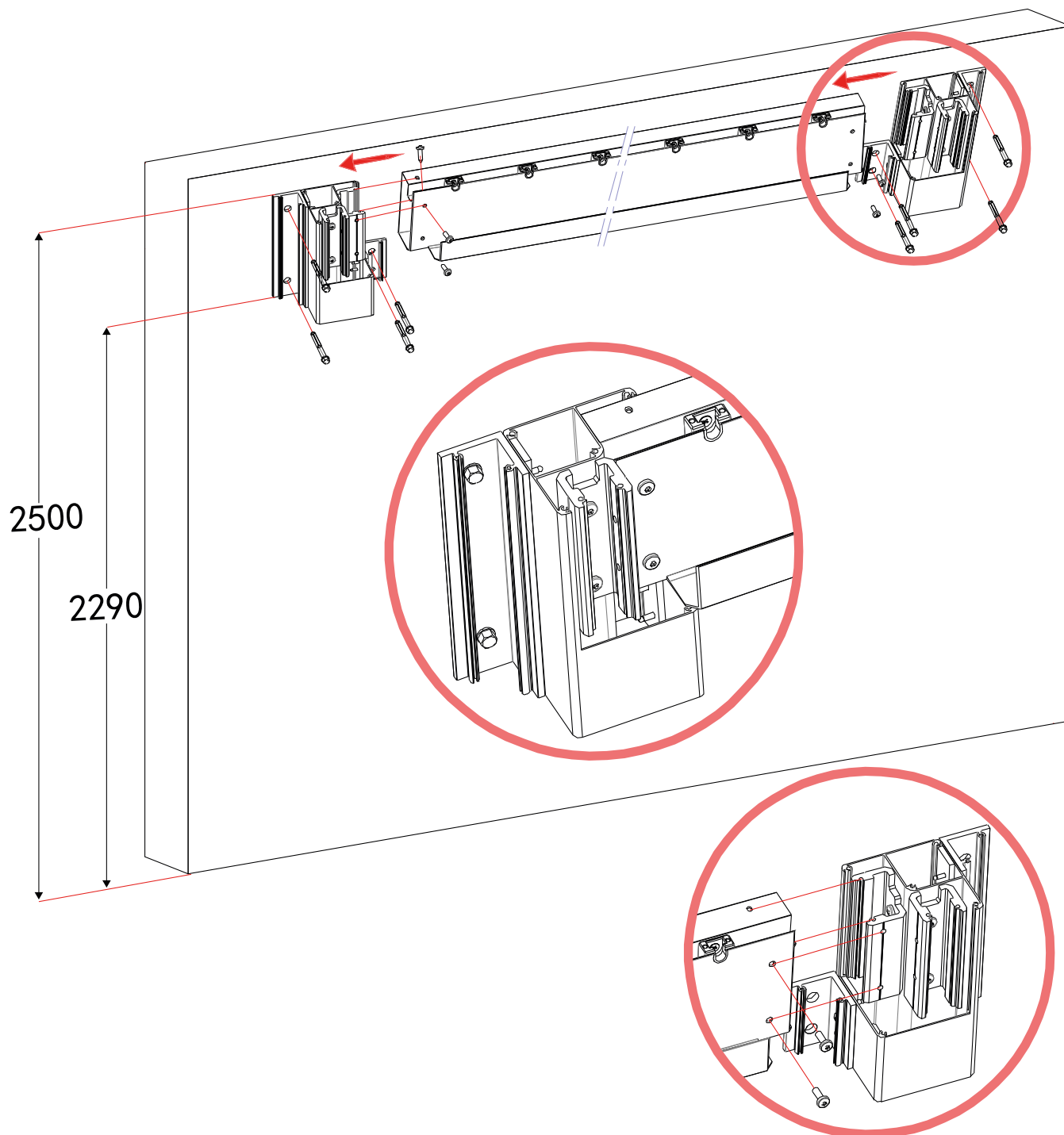

Tip:

Montieren Sie zuerst nur eine Wandhalterung und nutzen die entsprechende Querstrebe zur exakten Bestimmung des Abstandes zwischen den Wandhalterungen.

Stecken Sie dafür die Strebe in die montierte Wandhalterung und die zweite Wandhalterung auf die Strebe. Nun können Sie die Befestigungspunkte der zweiten Wandhalterung kennzeichnen.

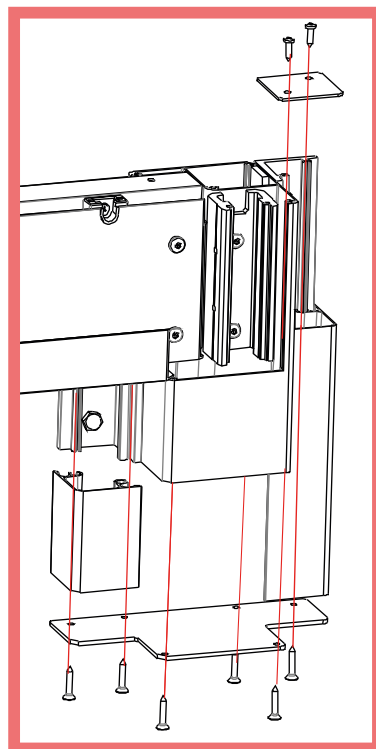
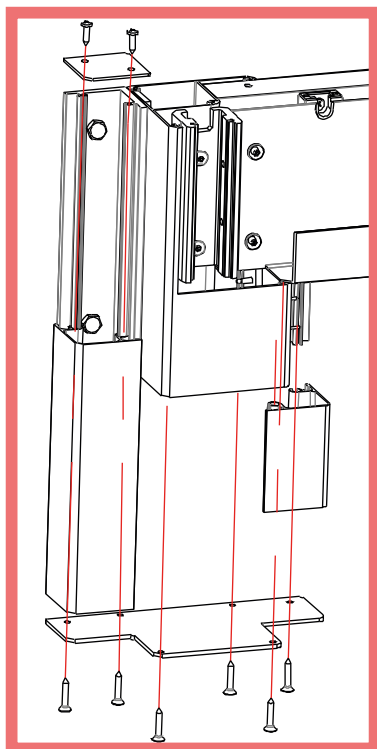

Aus Sicherheitsgründen nur mit Unterstützung mindestens einer weiteren Person arbeiten.



Wandhalterung 2

Wandhalterung 1

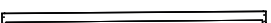
2500

LB  1x	RB  1x	E  M6X16 8x
--	--	---

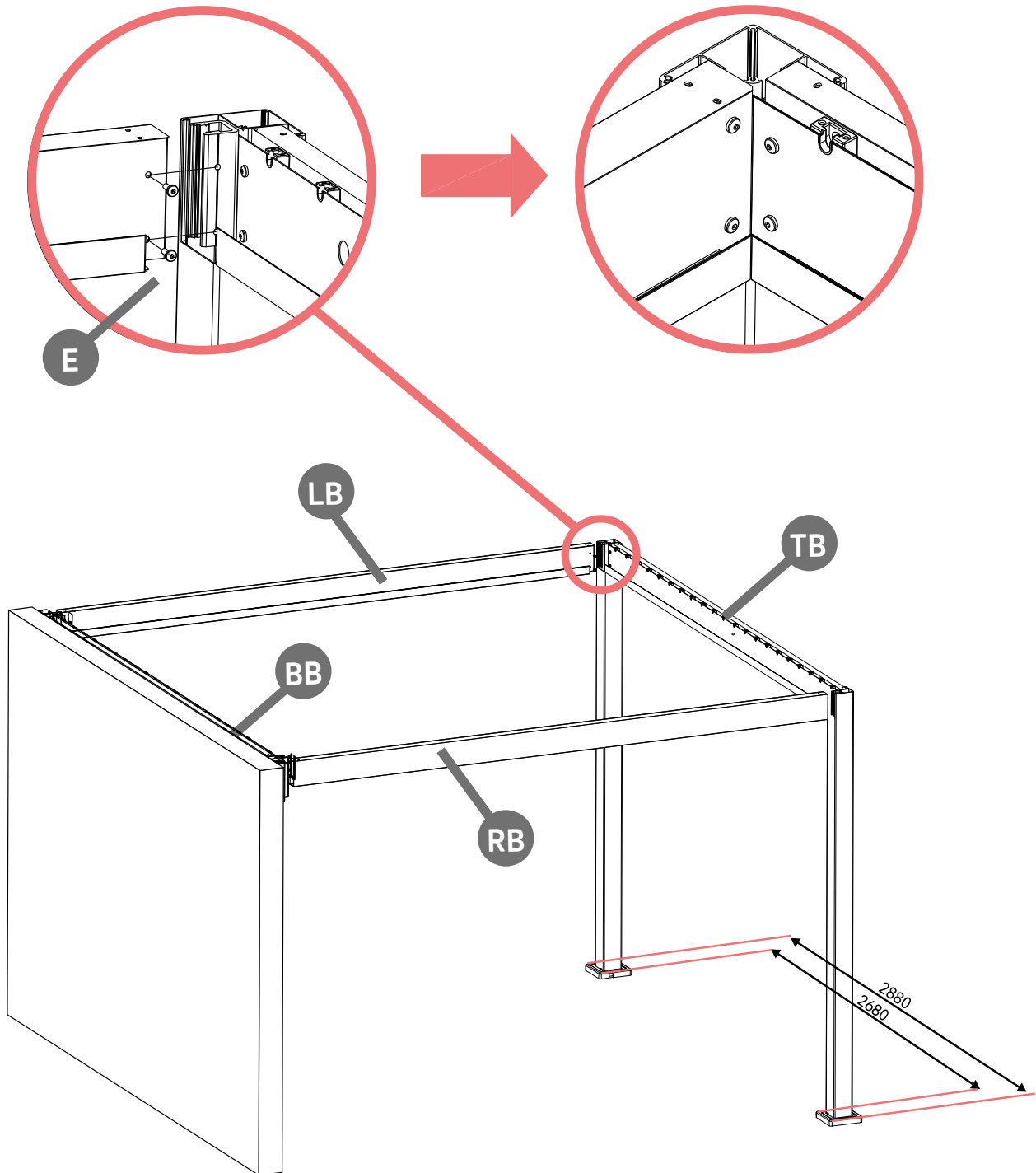



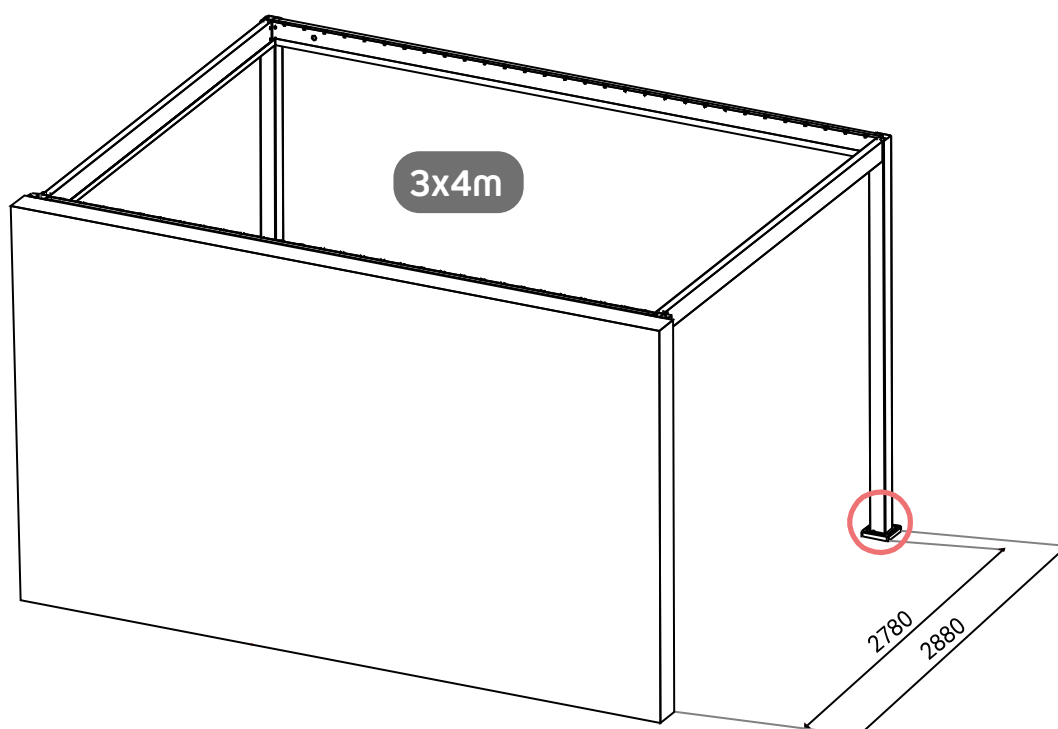
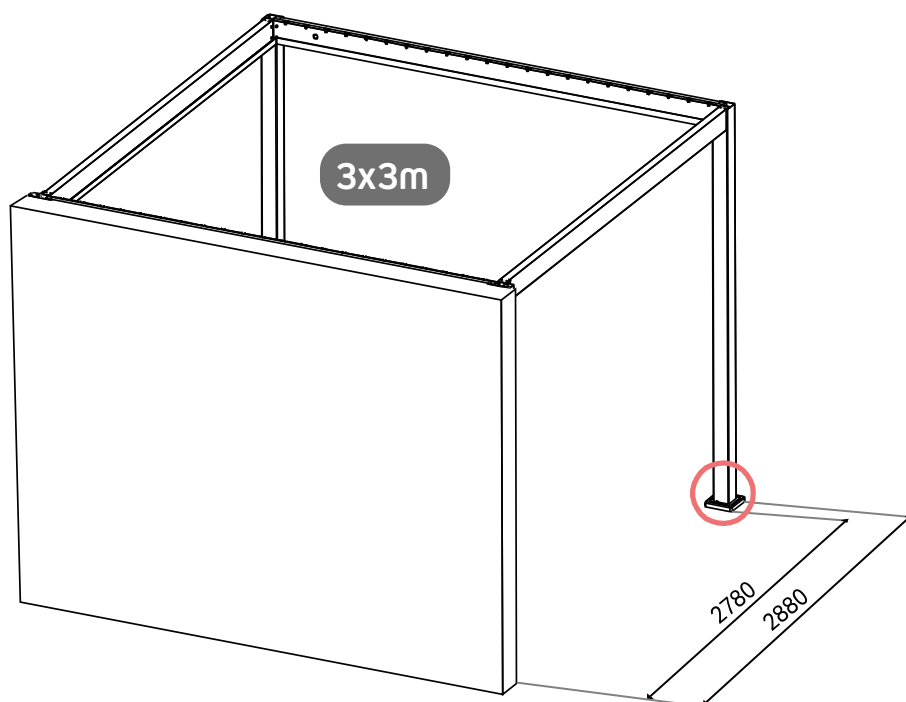
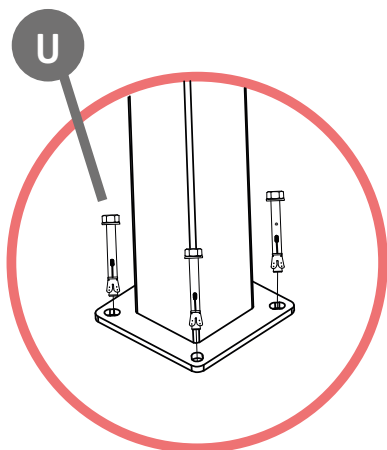

U

M10*100

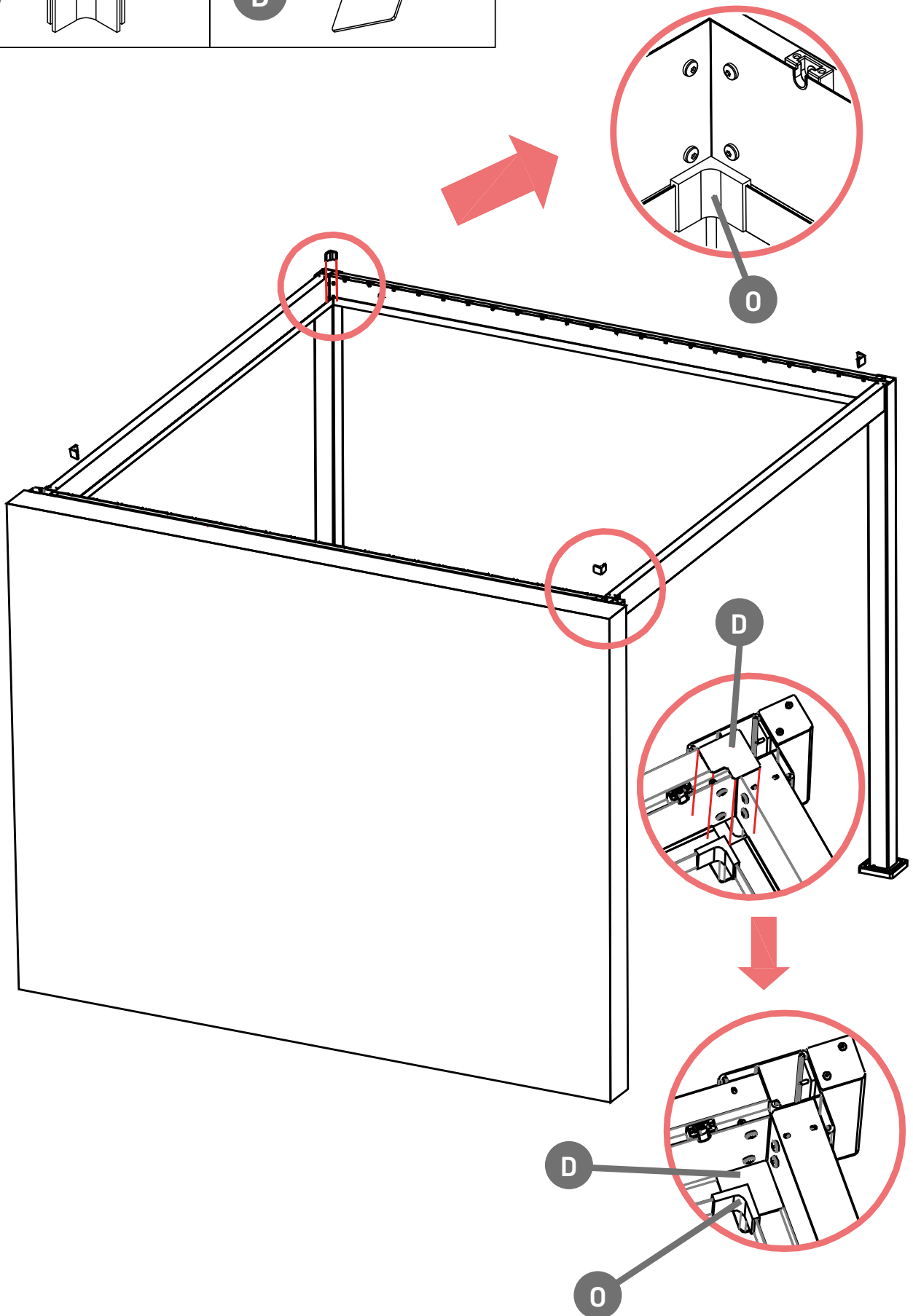
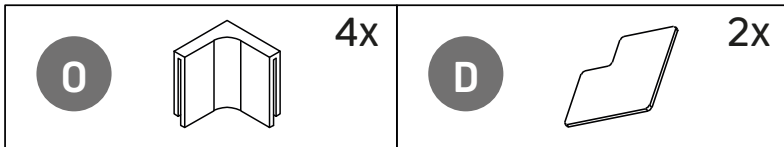

16x

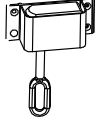
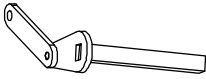

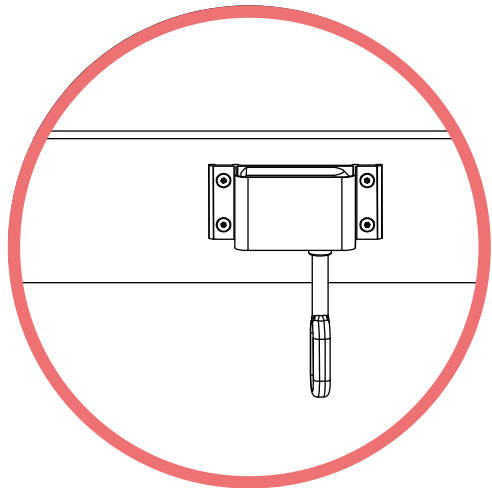
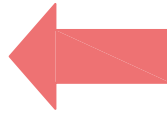
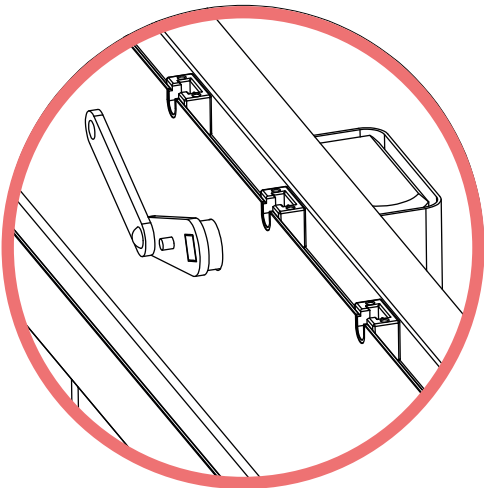
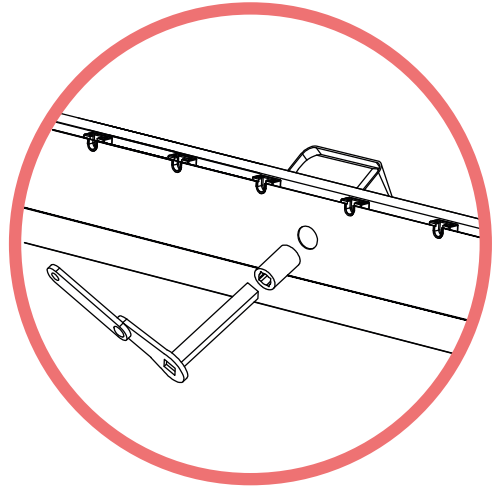
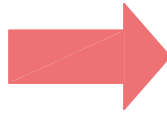
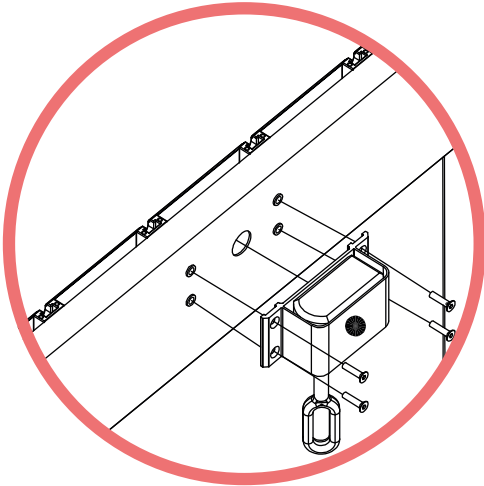

	 1x	 1x	 1x	 4x M6X25
---	--	--	--	---

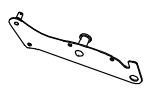

Lamelle		1x	G		1x		3x
---------	---	----	---	--	----	---	----

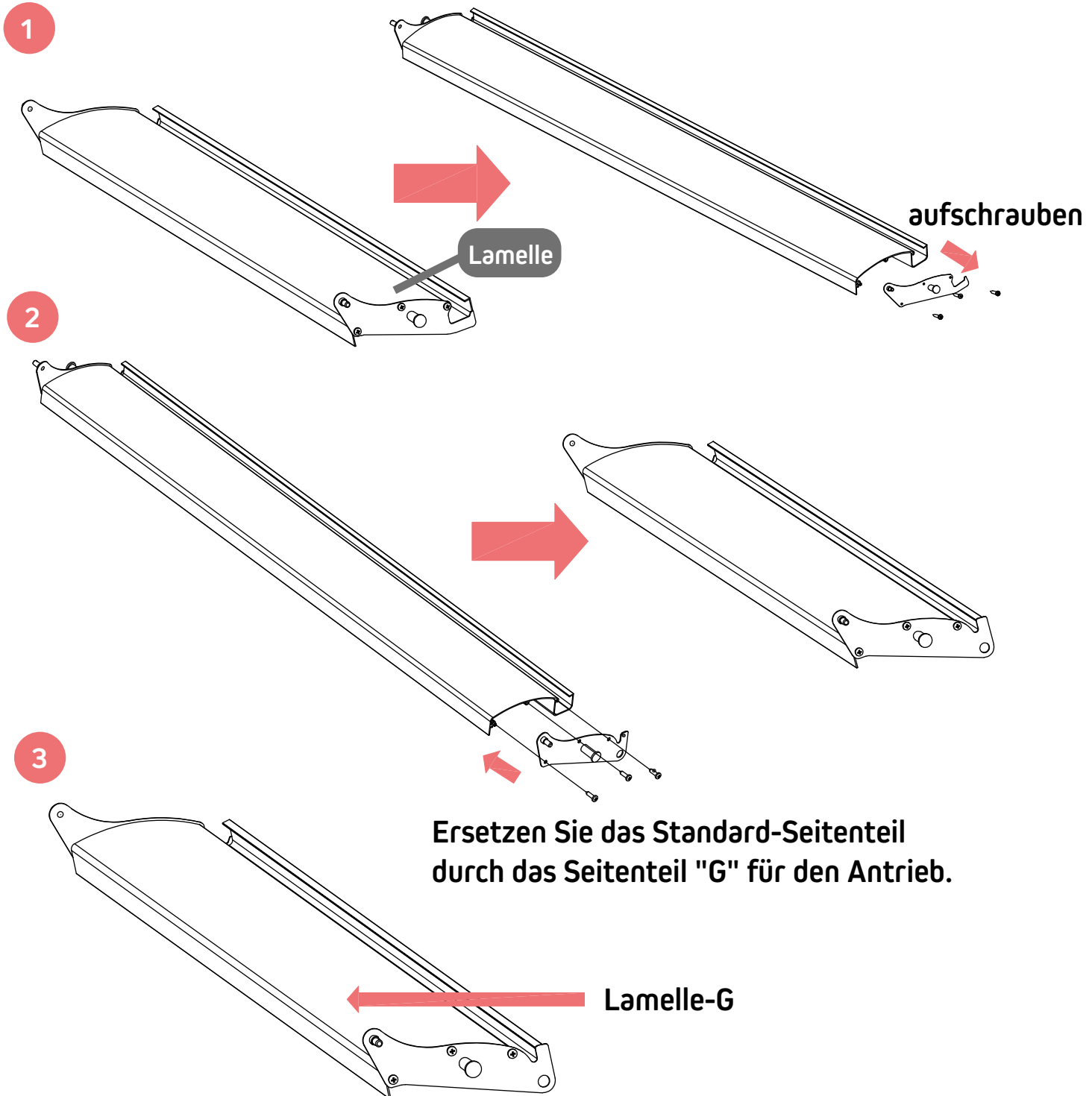

Lamellen	(3x3m) 20x (3x4m) 28x	Lamelle-G	1x	G3	1x
----------	--------------------------	-----------	----	----	----

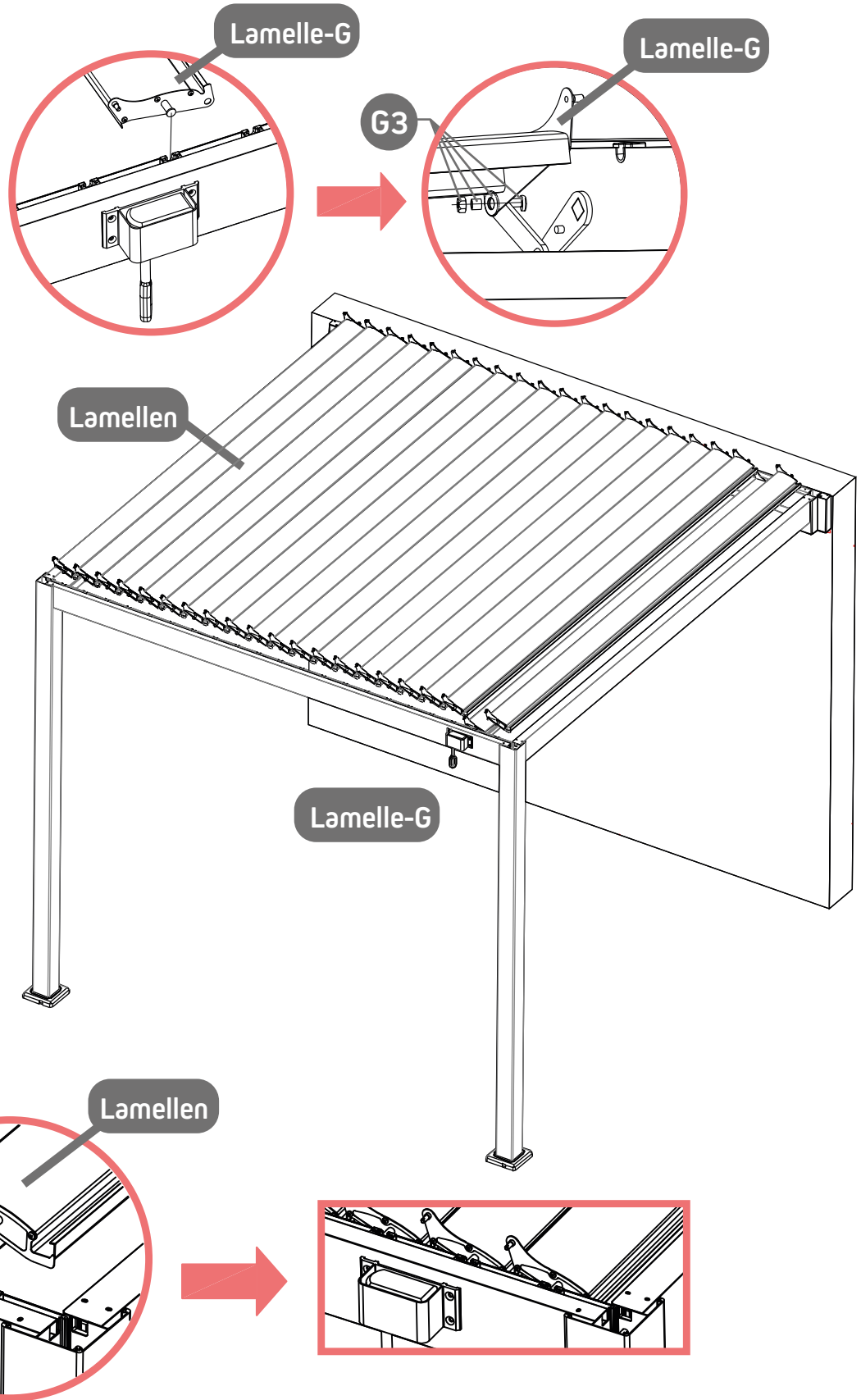

H



(3x3m) 84x
(3x4m) 116x



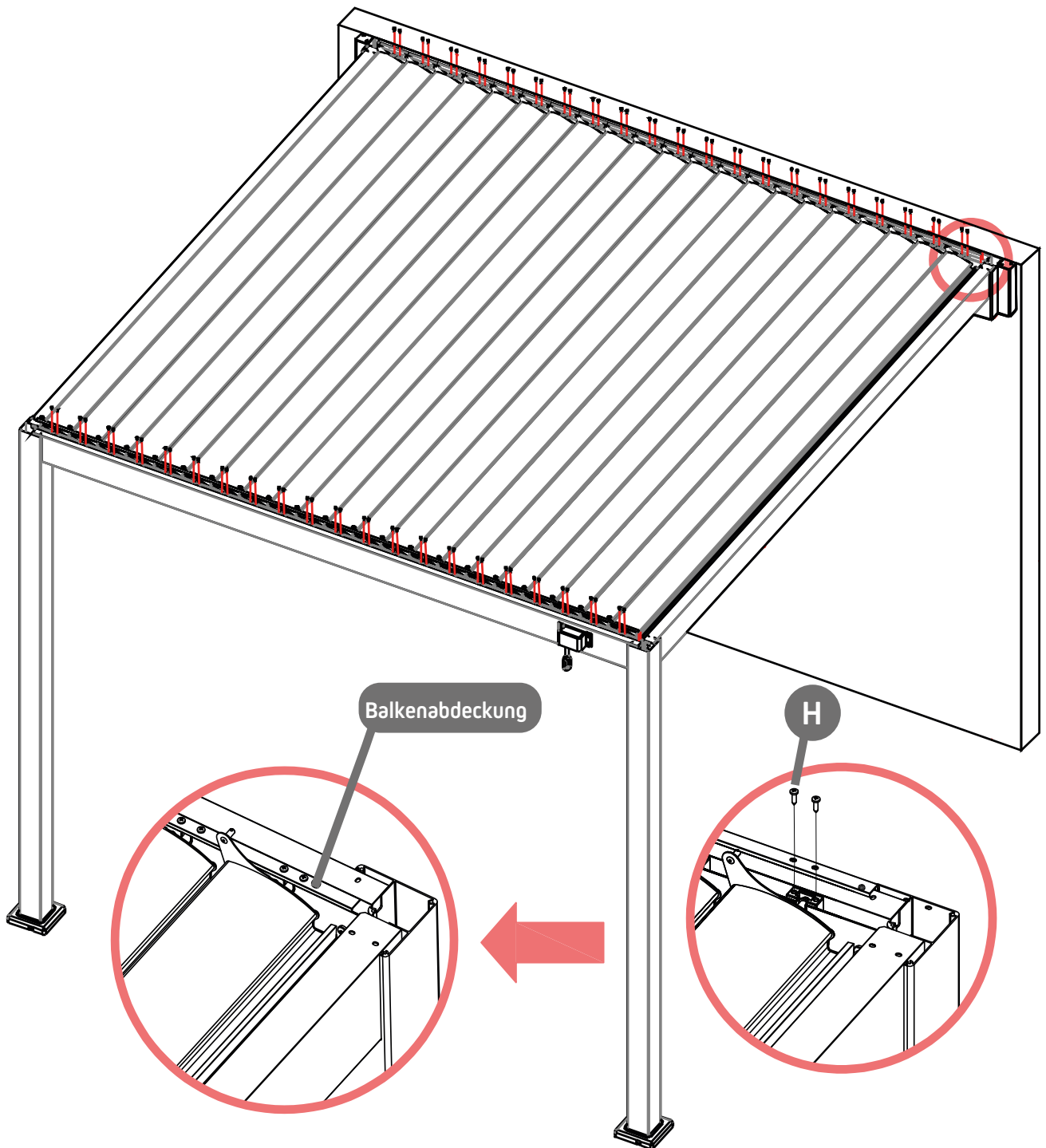

Balkenabdeckung

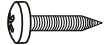
2x

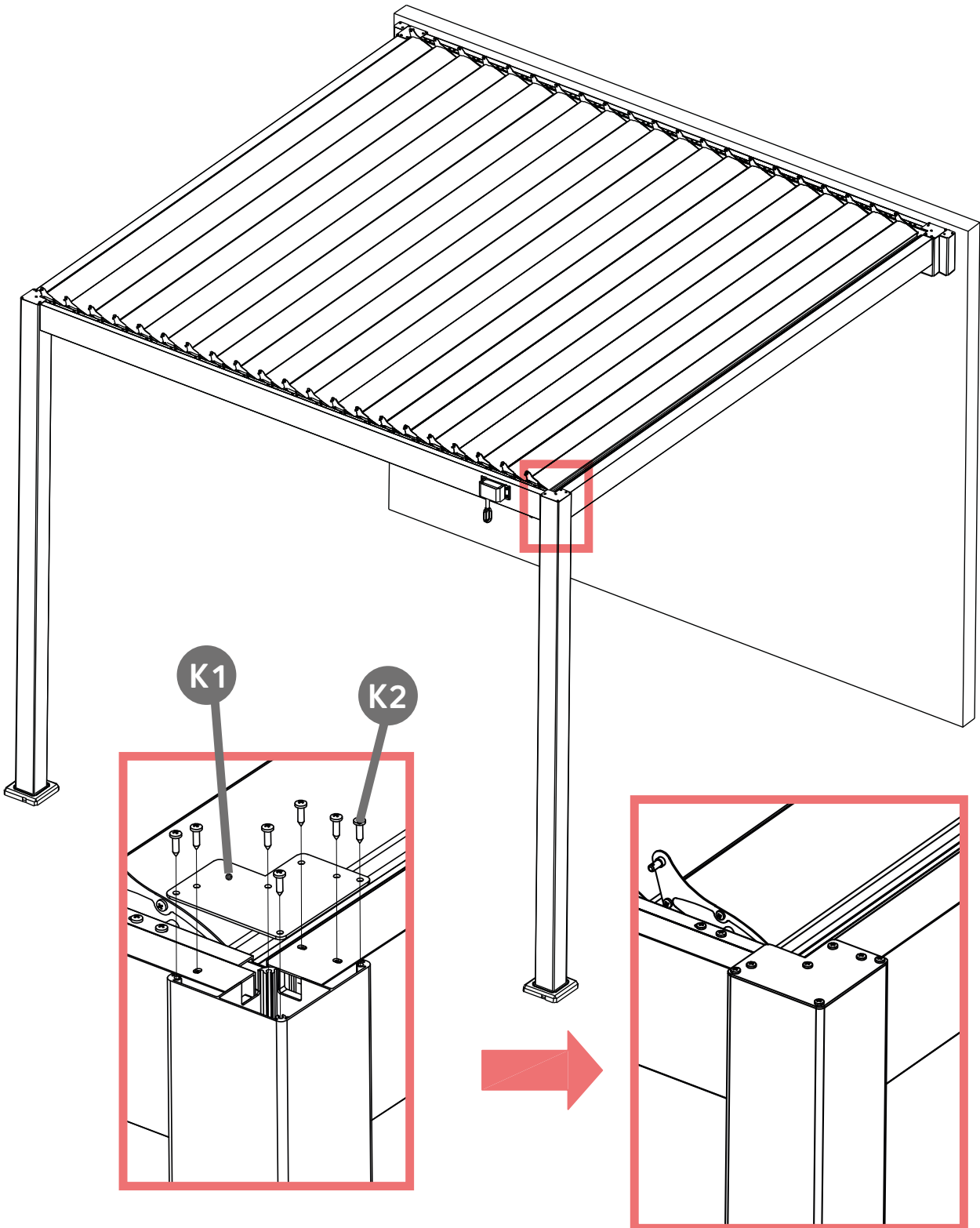

K1	 4x	K2	 ST4.2X16	28x
-----------	--	-----------	--	-----

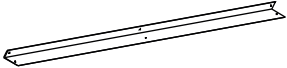

Zugstange		2x	R		Ø1.5X28	(3x3m) 42x (3x4m) 58x
F		1x	H		ST4.2X16	6x

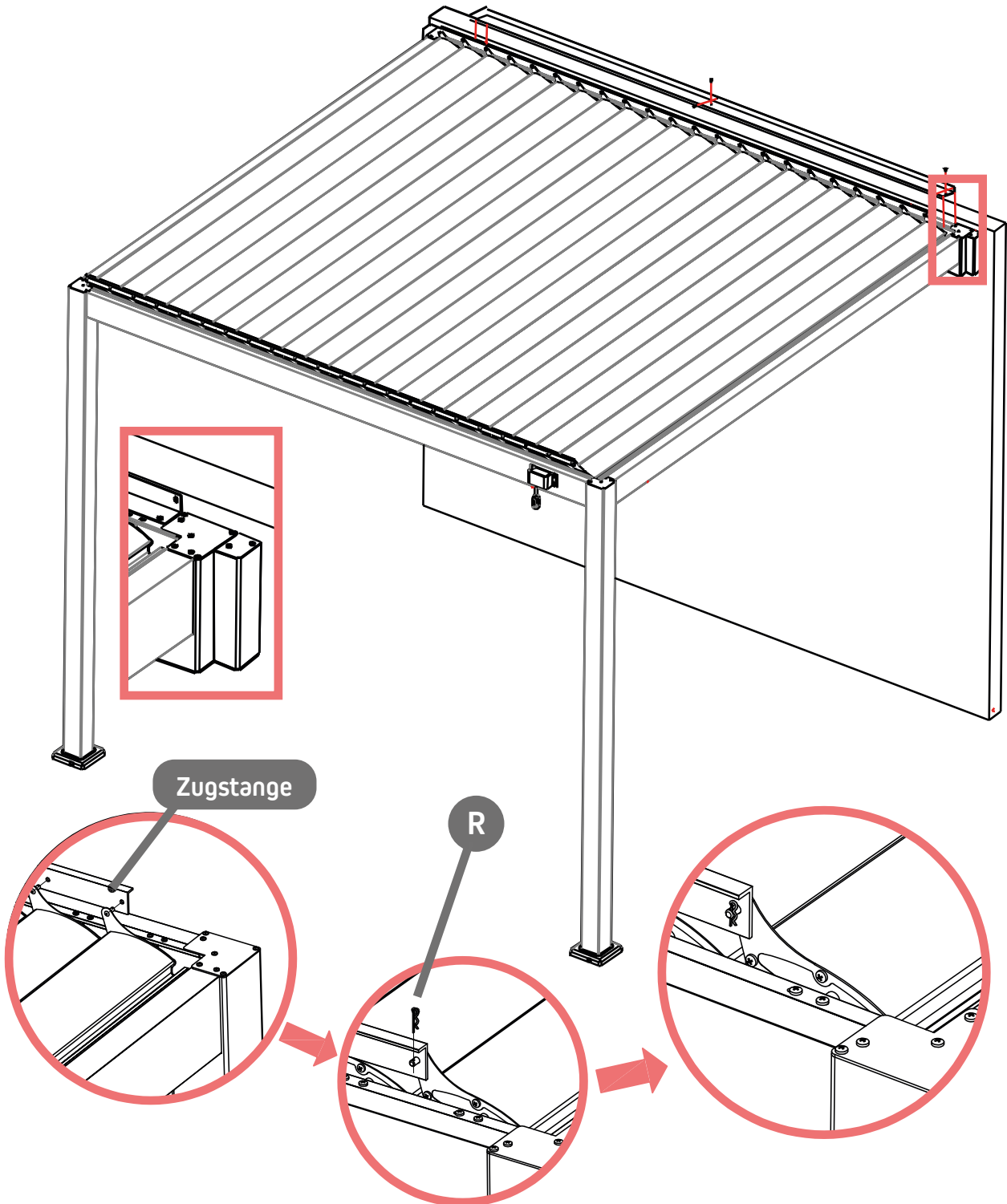

Handkurbel



1x

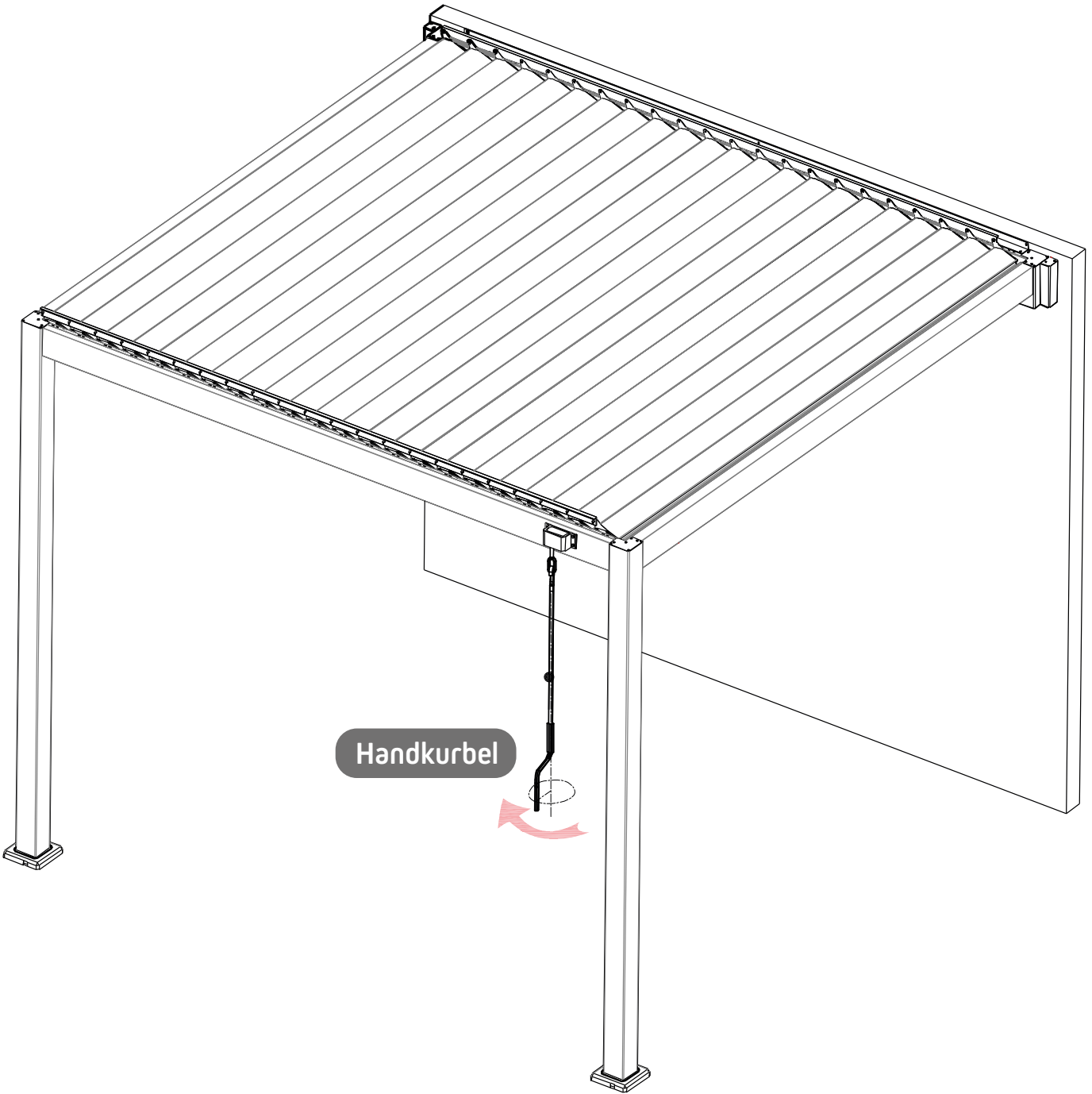

Handkurbel

Leistungserklärung-Nr.:	lei_sge_ce_pergomondo_20001017_2023_11_v01
Hersteller / Kontaktinformationen:	Schoenberger Germany Enterprises GmbH & Co. KG Zechstr. 1-7 82069 Hohenschäftlarn Tel.: +49 (0) 8178 932 932 info@schoenberger-group.com www.schoenberger-group.com
Marke:	pergomondo
Produkttyp:	Pergola mit Lamellendach

Eindeutiger Kenncode des Produkttyps:	2001017*
Baujahr ab:	11/2023
Verwendungszweck:	Anwendung im Außenbereich von Gebäuden und anderen Bauwerken
Maximale Abmessungen:	300 x 400 cm
Windwiderstandsklasse:	5
System zur Bewertung/Überprüfung der Leistungsbeständigkeit des Bauprodukts:	4

Die Leistung des vorstehenden Produkts entspricht der erklärten Leistung.
Für die Erstellung der Leistungserklärung im Einklang mit der Verordnung (EU) Nr.305/2011 ist allein der obengenannte Hersteller verantwortlich.
Diese Erklärung verliert ihre Gültigkeit bei nicht bestimmungsgemäßer Verwendung und bei Änderungen an der Anlage oder dem Produkt, die nicht mit dem Hersteller abgestimmt wurden.

EU-Richtlinien:	EU-Bauproduktenverordnung (305/2011 EU)
Angewandte/harmonisierte Normen:	EN 1090-1:2009 +A1:2011; Ausführung von Stahltragwerken und Aluminiumtragwerken - Teil 1: Konformitätsnachweisverfahren für tragende Bauteile;

Unterzeichnet für den Hersteller und
im Namen des Herstellers von

Michael Mayer
Geschäftsführer / CEO

Hohenschäftlarn
November 2023



*gültig für die Art.-Nr. (ID-Nummern) 1000024803, 1000024804, 1000024805, 1000024806, 1000024831, 1000024832, 1000024833, 1000024834, 1000024835, 1000024836, 1000024837, 1000024838.

Eine vollständige Liste der Ausführungen / Typen finden Sie in der Original-Erklärung auf:
<https://www.pergomondo.de/leistungs-konformitaetserklaerungen/>

Dokument Nr.:	kon_sge_ce_pergomondo_20001017_2023_11_v01
Hersteller / Kontaktinformationen:	Schoenberger Germany Enterprises GmbH & Co. KG Zechstr. 1-7 82069 Hohenschäftlarn Tel.: +49 (0) 8178 932 932 info@schoenberger-group.com www.schoenberger-group.com
Marke:	pergomondo
Produkttyp:	Pergola mit Lamellendach

Eindeutiger Kenncode des Produkttyps:	2001017*
Baujahr ab:	11/2023
Verwendungszweck:	Anwendung im Außenbereich von Gebäuden und anderen Bauwerken
Maximale Abmessungen (Breite / Ausfall):	300 x 400 cm
Windwiderstandsklasse:	5

Wir, die Schoenberger Germany Enterprises GmbH & Co. KG, erklären, dass das oben genannte Produkt in seiner Konzipierung und in der von uns in Verkehr gebrachten Ausführung den einschlägigen grundlegenden Leistungs- und Sicherheitsanforderungen entspricht, wie sie in den unten genannten EU-Richtlinien vorgeschrieben sind. Diese Erklärung verliert ihre Gültigkeit bei nicht bestimmungsgemäßer Verwendung und bei Änderungen am System oder Produkt, die nicht mit dem Hersteller abgestimmt wurden.

EU Richtlinien:	Maschinenrichtlinie 2006/42/EG
Angewandte/harmonisierte Normen:	EN 1090-1:2009 +A1:2011; Ausführung von Stahltragwerken und Aluminiumtragwerken - Teil 1: Konformitätsnachweisverfahren für tragende Bauteile;

Unterzeichnet für den Hersteller und
im Namen des Herstellers von

Michael Mayer
Geschäftsführer / CEO

Hohenschäftlarn
November 2023



*gültig für die Art.-Nr. (ID-Nummern) 1000024803,1000024804, 1000024805, 1000024806, 1000024831, 1000024832, 1000024833, 1000024834, 1000024835, 1000024836, 1000024837, 1000024838.

Eine vollständige Liste der Ausführungen / Typen finden Sie in der Original-Erklärung auf:
<https://www.pergomondo.de/leistungs-konformitaetserklaerungen/>



Eine aktuelle Version dieser Anleitung finden Sie auf:
<https://www.pergomondo.de/anleitungen/>

A current version of these instructions can be found on:
<https://www.pergomondo.de/anleitungen/>

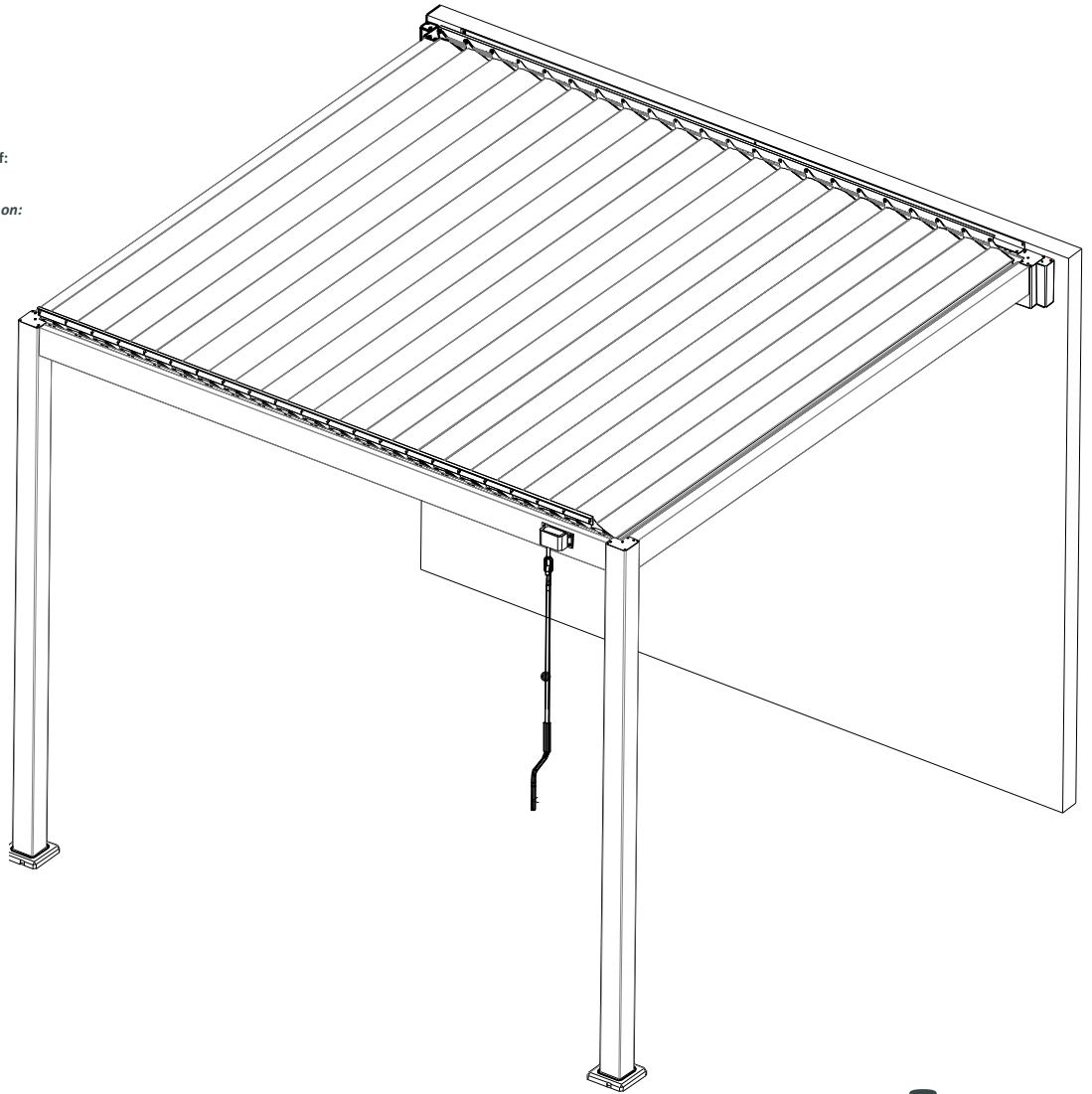

pergomondo

Wall mounting bracket set for
pergola with slatted roof 3x3 m / 3x4 m

Montageanleitung / installation instructions

Reading the fitting and operating instructions

Read the fitting and operating instructions (hereinafter also referred to as manual) prior to fitting and adhere to them.

Failure to observe the fitting and operating instructions relieves the manufacturer from any liability.

This manual was prepared as the basis for fitting, installing and maintaining the product listed on Page 1.

You must not amend the manual or modify the pages.

The manufacturer reserves the right to change the product and content of these instructions at any time without prior notice.

You must keep complete manual in an easily accessible place at all times and hand it to the new owner in the case of the product being sold to a third party.

Warning symbols

Safety notices and important information are placed in the corresponding locations and must be marked with a symbol.



This symbol marks notices that are important to personal safety or the correct functioning of the product.



This symbol marks important product information for the fitter or user.



This symbol marks references to special dangers to persons and/or the product and its accessories. Failure to comply may result in serious injuries or death, e.g. due to electric shock.

Fitting information

At least 3 people are required to assemble the 3x3 m pergola and at least 4 people are required for the 3x4 m variant.

We recommend a maximum lifting weight of 15kg for females and 25kg for males.



Storage

The packaging of the product must be protected against wet and damp. Soaked packaging can come loose and cause accidents.

The product must be protected against penetrating damp when in storage!

The cartons must be stacked and unstacked so that they do not prove a hazard to persons due to tipping over or rolling out of position.

Only create storage facilities and stacks that can securely take the load. Ensure that the permissible loads of shelves and other load-bearing components are not exceeded. You must comply with the general goods storage principles.



Assembly

You need the following equipment in order to guarantee that the product is properly fitted, and therefore the optimal functioning of the finished product:

- Cordless screwdriver
- Complete tool set
- Gloves
- Silicone
- Equipment for working at height (scaffolding, ladders, cherry picker, etc.), that meet the current individual occupational health and safety standards.

Ensure that all screws are tightened evenly. A greater tightening force may damage the components and/or the stainless-steel screws.

Uneven tightening can result in tension in the aluminum and cast components as well in the brickwork and therefore lead to failure of the attachments.

Assembly must be carried out in accordance with the applicable guidelines and standards for occupational safety.

Check all equipment (scaffolding, ladders, tools, etc.) and safety equipment (belts, ropes, etc.) before the use. Always use suitable protective equipment (gloves, safety boots, goggles, hearing protection, etc.).

Wall mounting

Selecting the most appropriate fastener depends on the type of wall and its physical condition. Before installing the pergola, please check the condition of the wall.

The mounting material for wall mounting is not included in the scope of delivery.



Fastening material

The wall mounting set is delivered without fastening material!

The mounting material must be selected by the installer for the existing mounting surface and tailored to the requirements of the system and the mounting surface.

The required dowel pull-out forces must be strictly adhered to. We assume no liability for the fastening material. The installer alone is liable for ensuring that the fastening material is suitable for the respective installation surface and that the installation is carried out professionally.

The respective installation instructions from the dowel manufacturers must be observed!

Cleaning and care instructions

Temperature fluctuations and humidity can lead to the formation of condensation in or outside the product, which does not mean that the product is leaking.

Check the stability of your pergola periodically, especially in autumn and winter. Remove leaves, stones, branches, and other objects from the pergola. As soon as snow accumulates on the roof, it must be removed immediately.

There are no warranty claims in the event of weather-related damage such as snow or storms.

Do not use strong cleaning agents such as solvents or corrosive liquids to clean your pergola. Wipe it with a damp cloth.







Warning

Keep packaging materials out of the reach of children and dispose them immediately. There is a risk of suffocation.



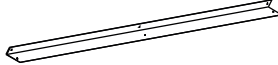







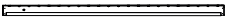
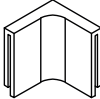

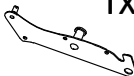







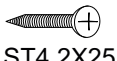

If it turns out unexpectedly that your product is defective or parts are missing, please contact our customer service. Please have your order number ready.

Our team will be happy to answer any further questions you may have, e.g. about the many extension options of our pergola.

Included in this wall mounting kit:

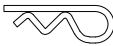
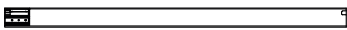
K		4x	F		1x
Wall bracket 1		1x	D		2x
Wall bracket 2		1x			

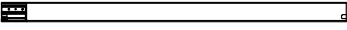
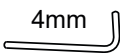
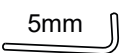
These parts are supplied with your pergola and are listed and shown in these instructions only to illustrate the assembly steps:

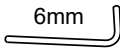
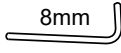
TB		1x	O		4x
BB		1x	G	 1x  3x  1x ST4.2X20	
LB		1x	V	 1x  1x  1x  4x M6X25	
RB		1x	B	 4x  20x ST4.2X25	
Control Bar		2x	C		4x
Beam Cover		2x	H	 ST4.2X16 (3x3m) 102x (3x4m) 130x	
Hand Crank		1x	R	 Ø1.5X28 (3x3m) 42x (3x4m) 62x	
Post 1		2x	E	 M6X16	16x
Post 2		2x		 2x	 2x
Blade		(3x3m) 21x (3x4m) 29x		 1x	 1x

Post 1

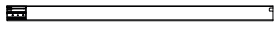

2x

B



2x



10x

ST4.2X25

C

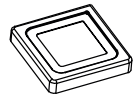

2x

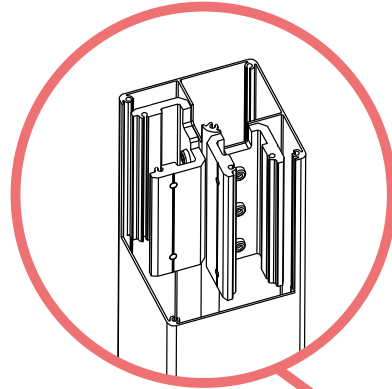

Post 1

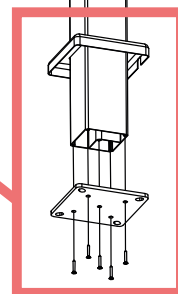
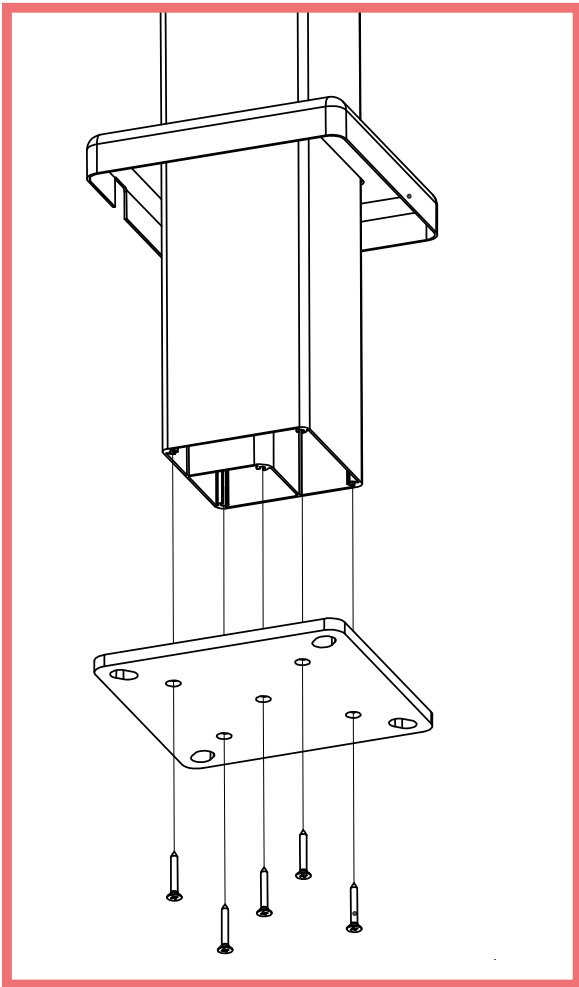
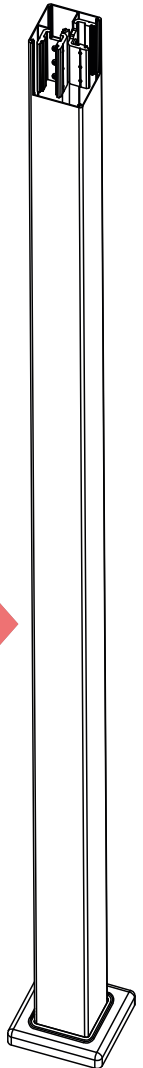
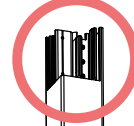

Post 2

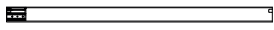

2x

B



2x



10x

C

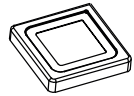

2x

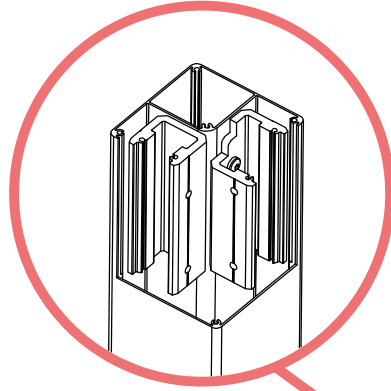

Post 2

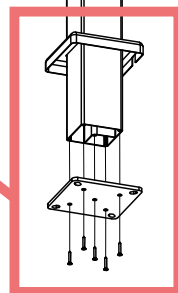
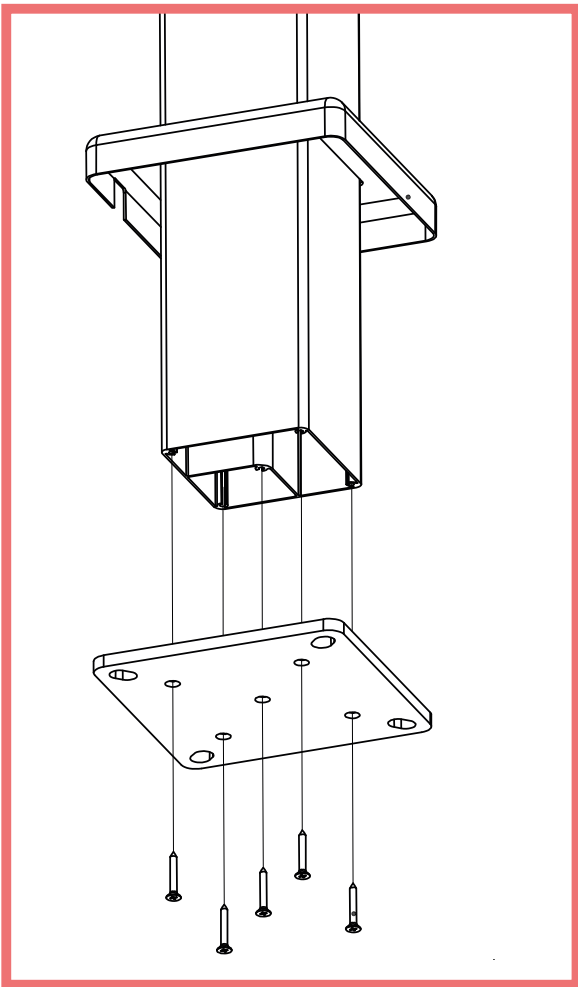
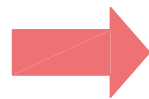
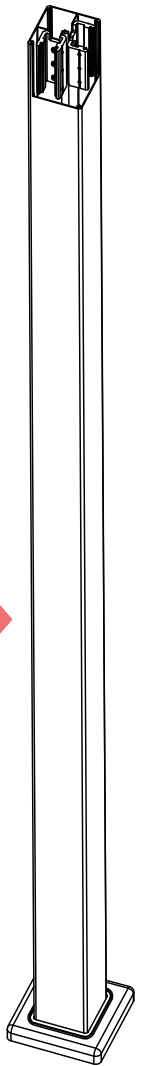
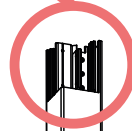

Wall bracket 1



1x

Wall bracket 2



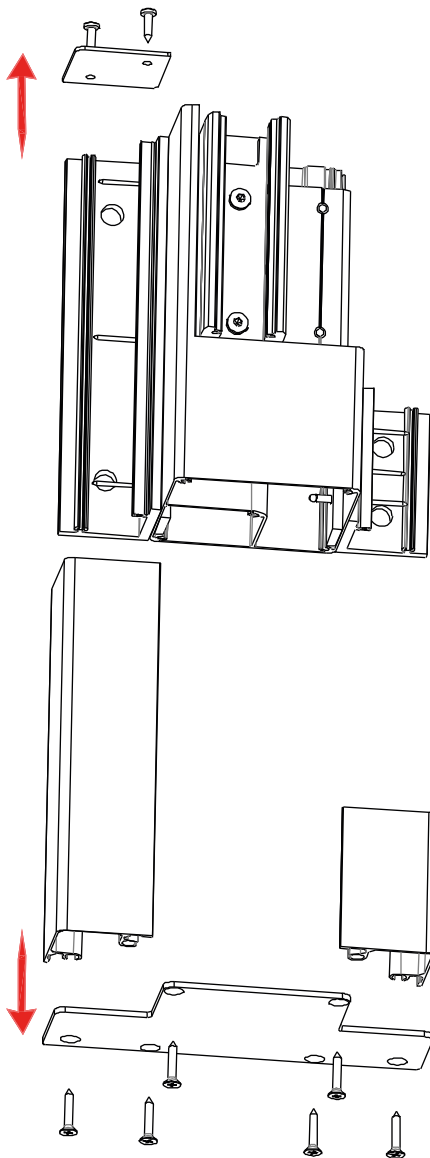

1x

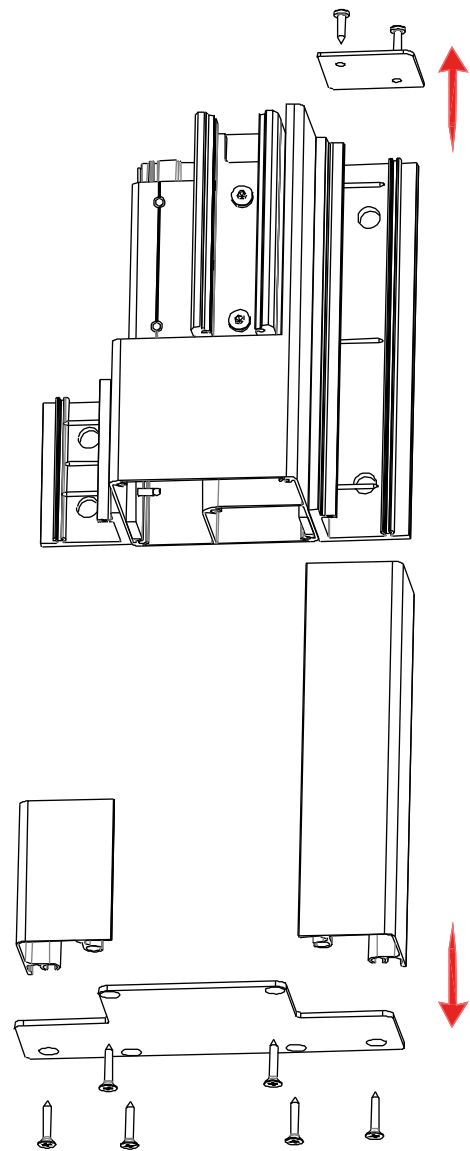

unscrew

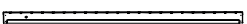

<p>TB  1x</p>	<p>E  M6X16 4x</p>	<p>H  ST4.2X16 2x</p>
---	--	---

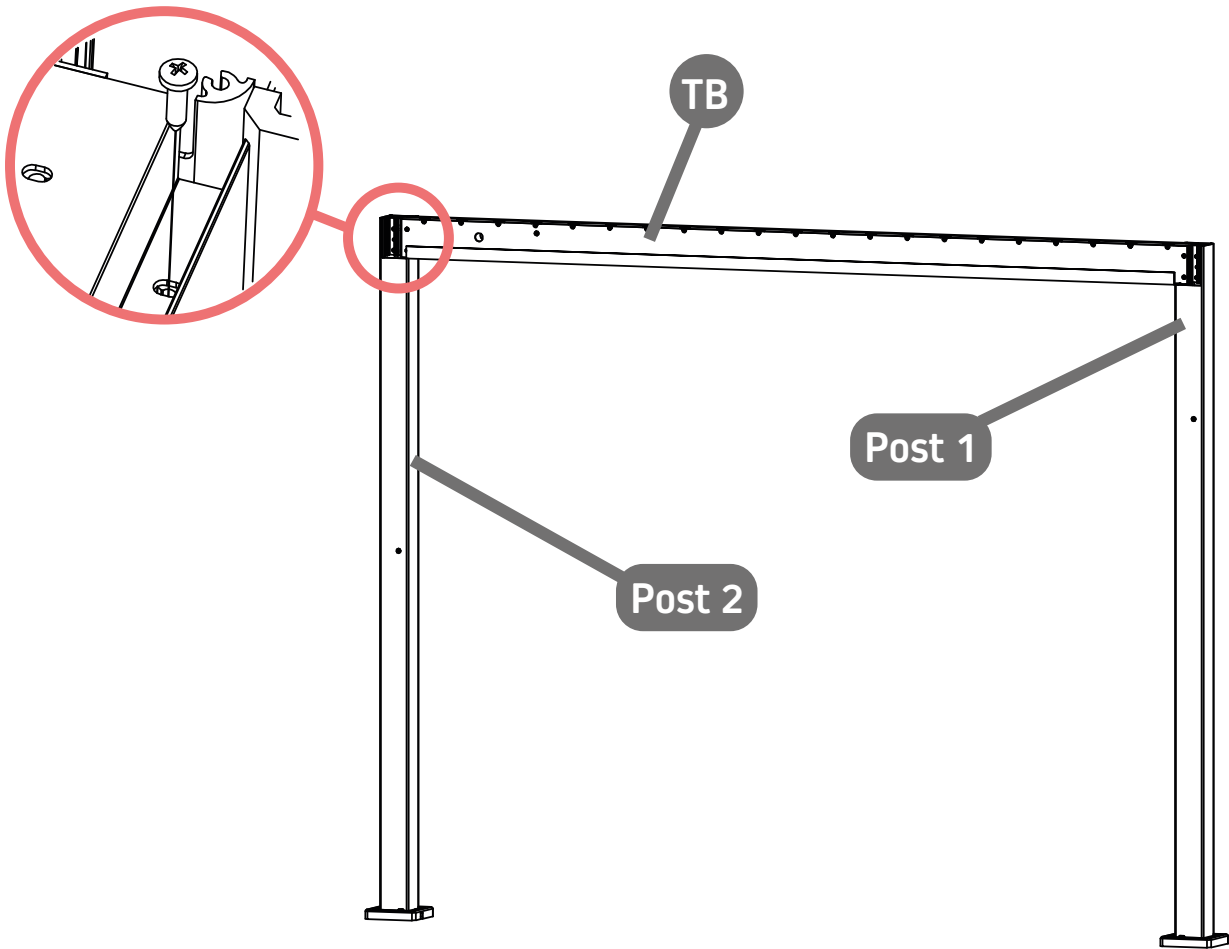
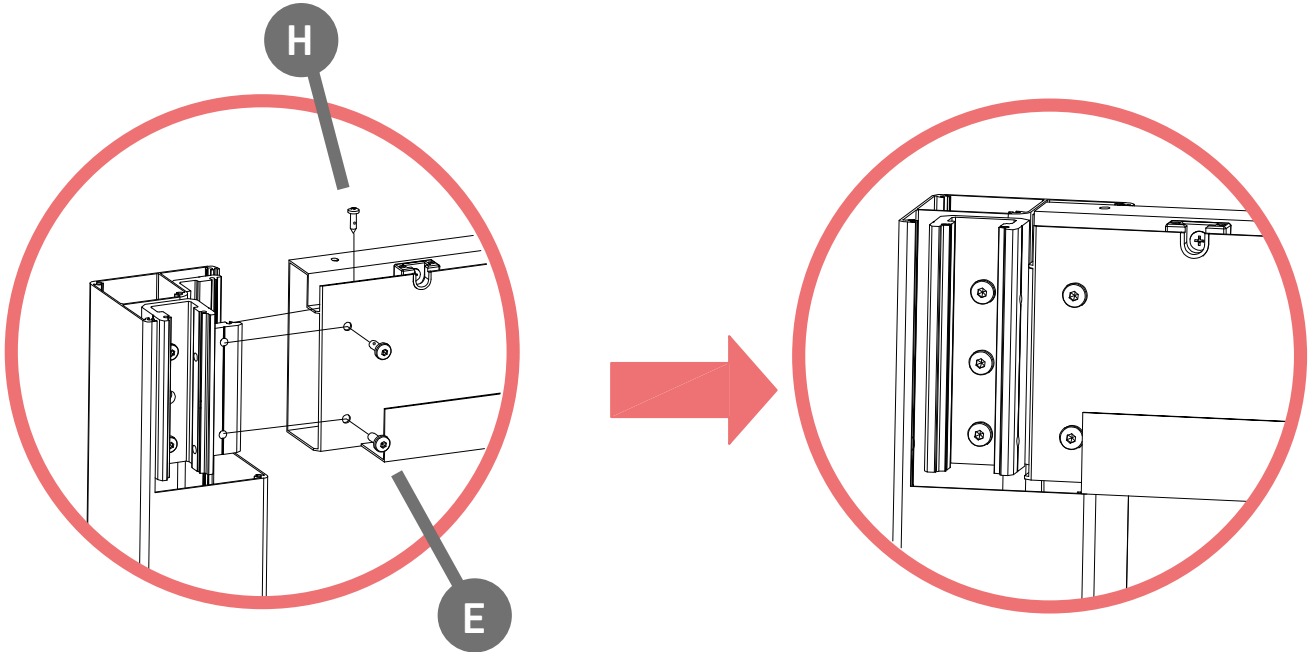

BB



1x

E



M6X16

4x

*) The fastening material for the Wall mounting is not included (see page 4)

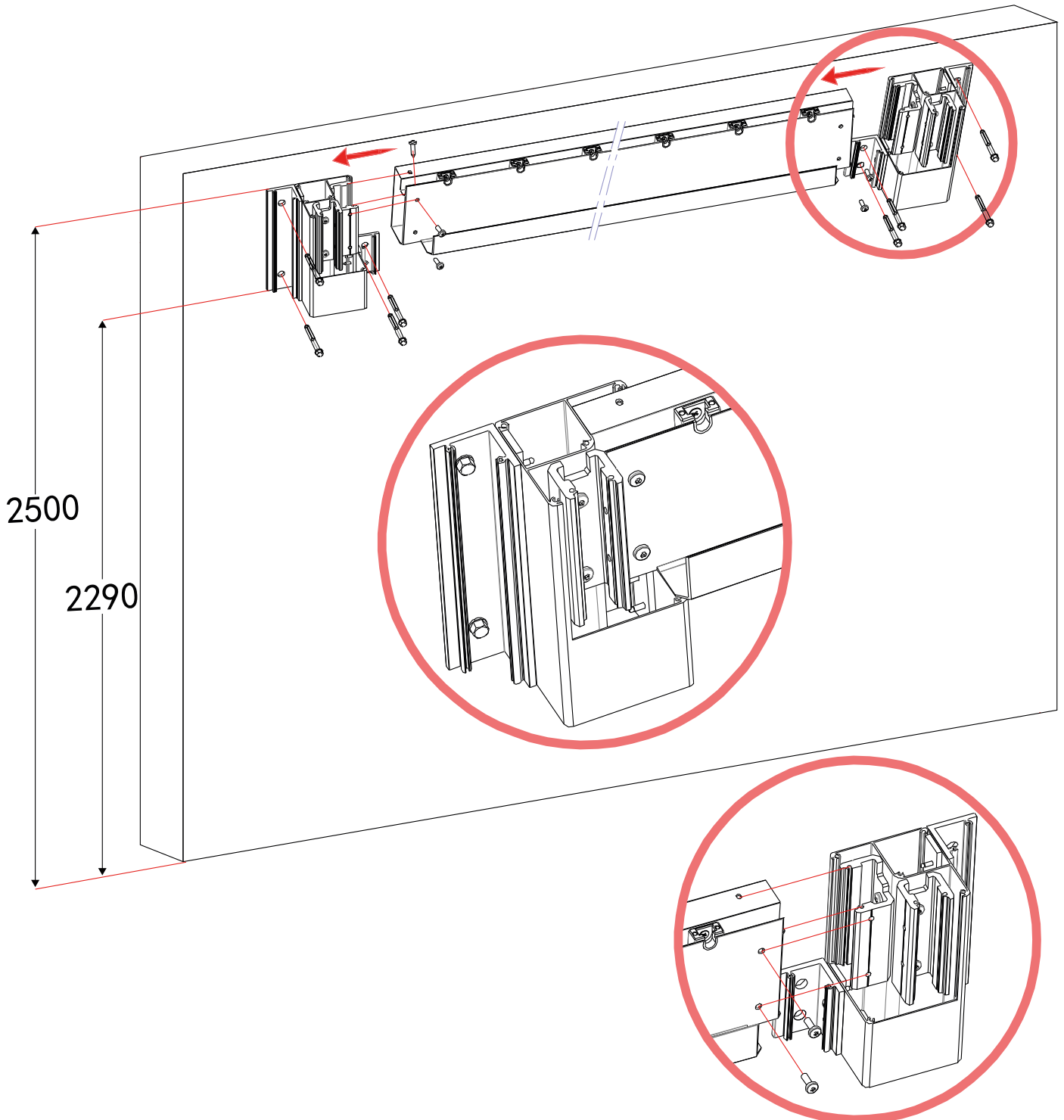



Advice:

First mount only one wall bracket and use the corresponding cross brace to precisely determine the distance between the wall brackets.

To do this, insert the strut into the mounted wall bracket and the second wall bracket onto the strut. Now you can mark the attachment points of the second wall bracket.

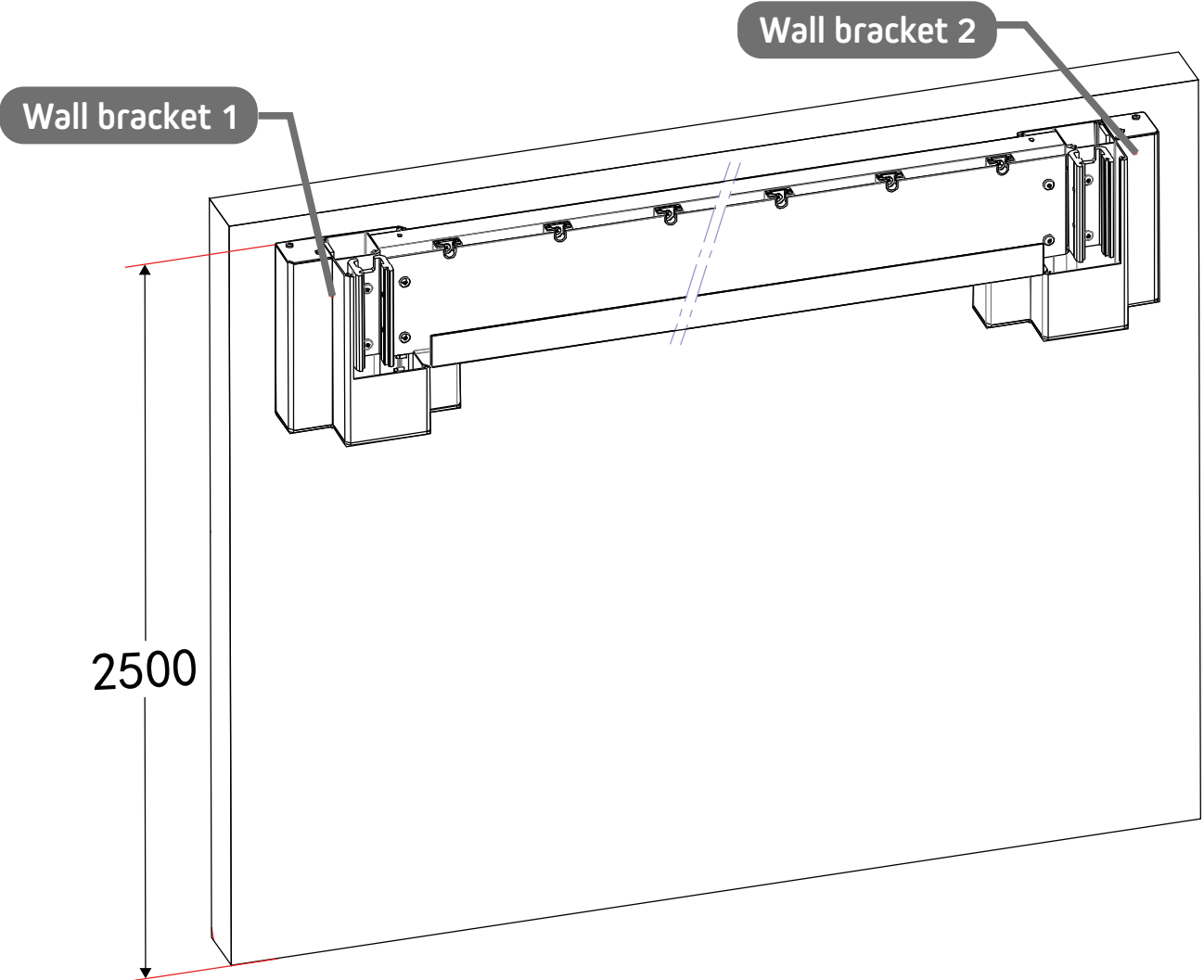
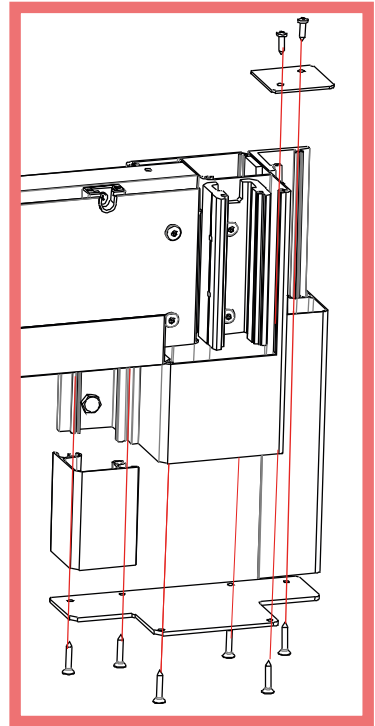
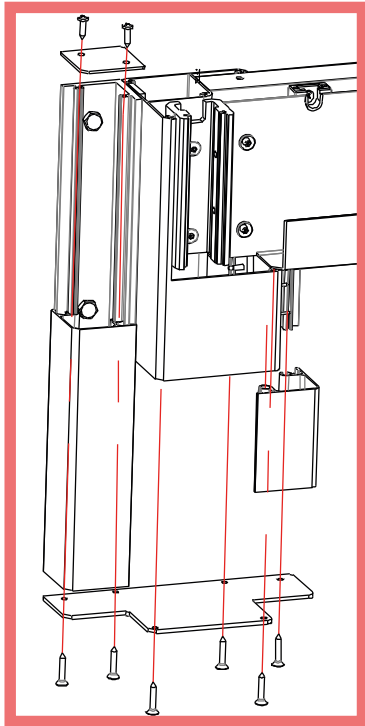
For safety reasons, only work with the support of at least one other person.

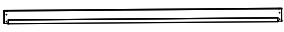
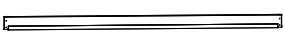

 <p>LB 1x</p>	 <p>RB 1x</p>	 <p>E M6X16 8x</p>
---	---	--

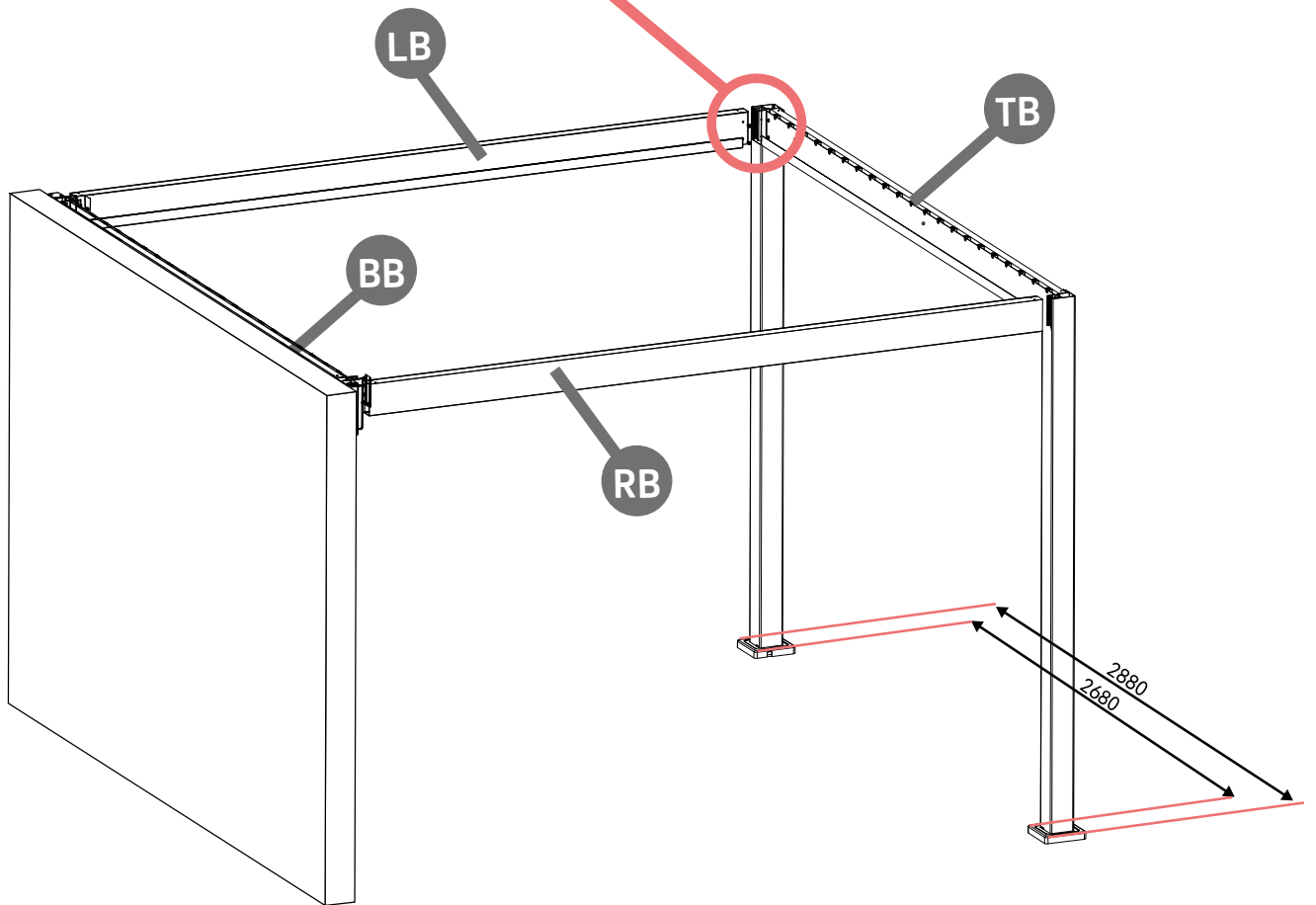
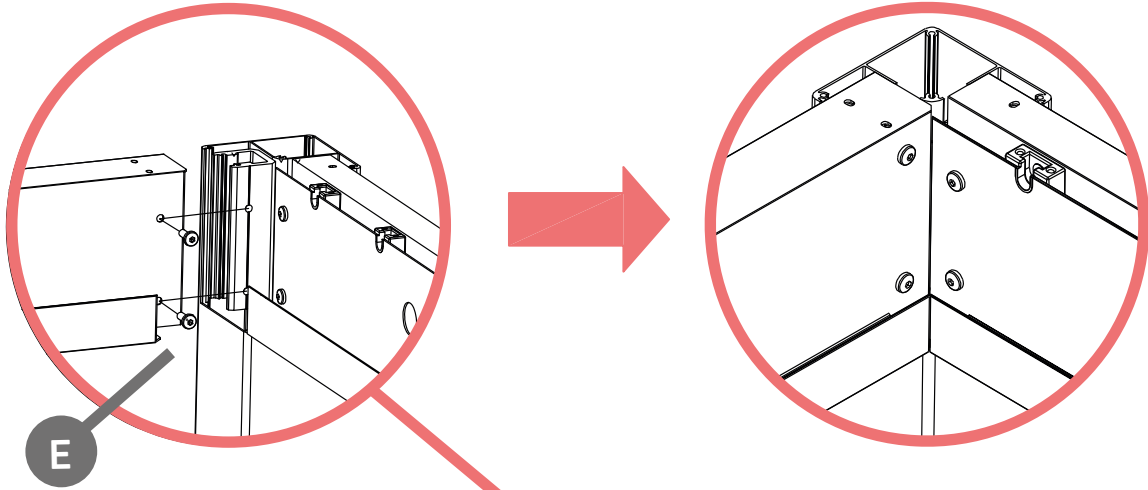

U

M10*100

16x

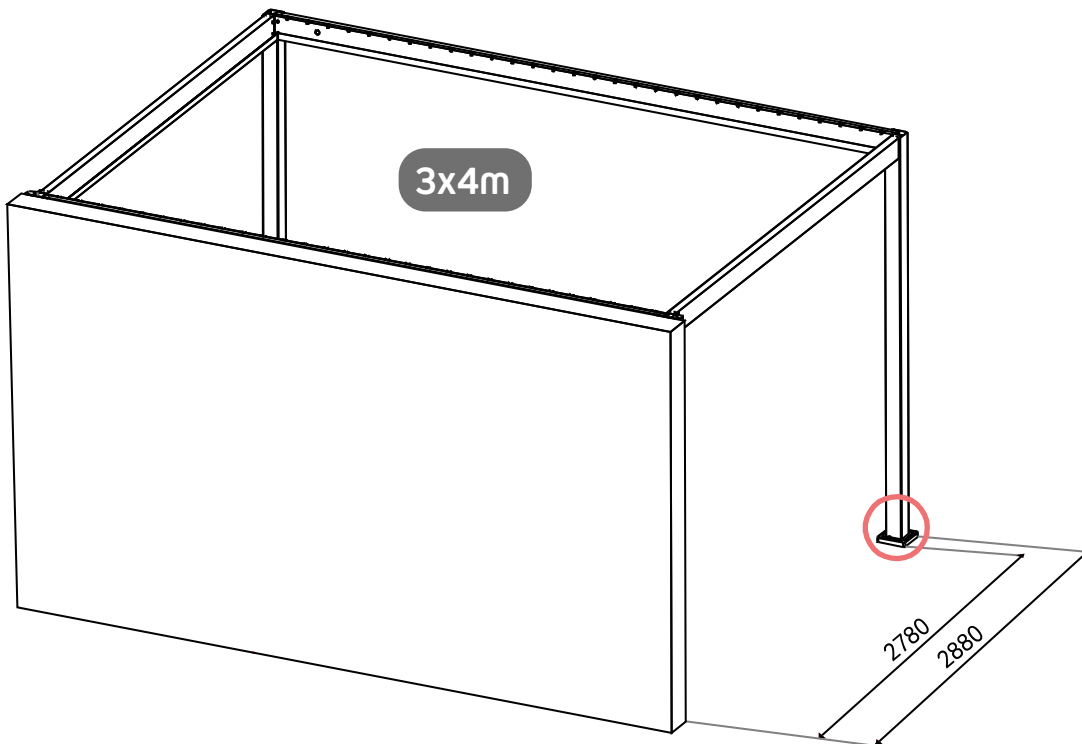
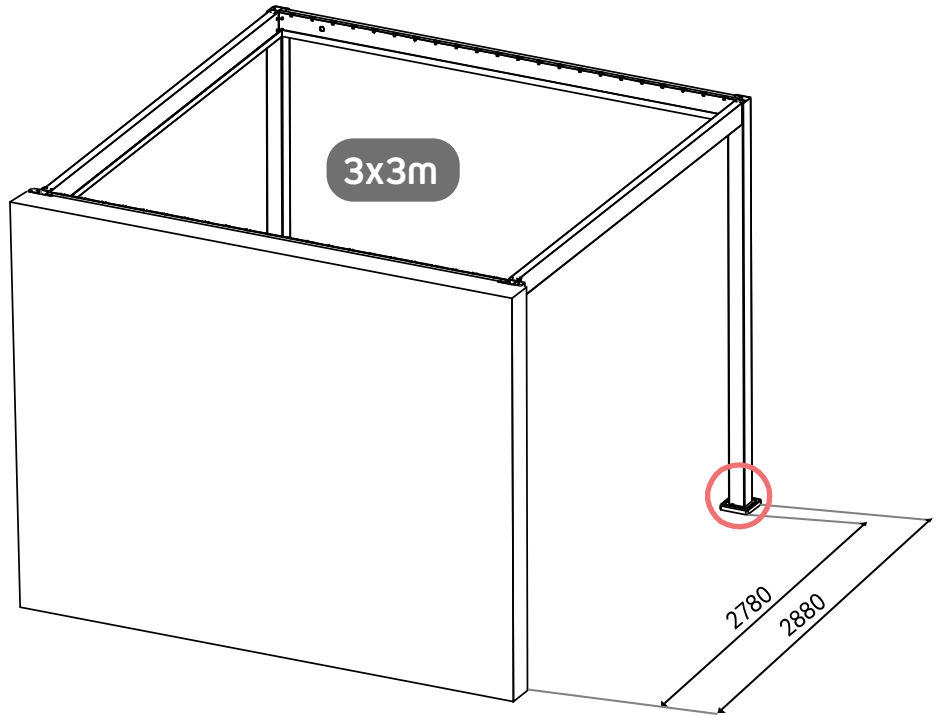
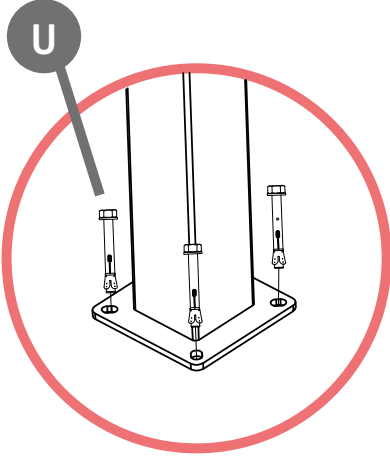

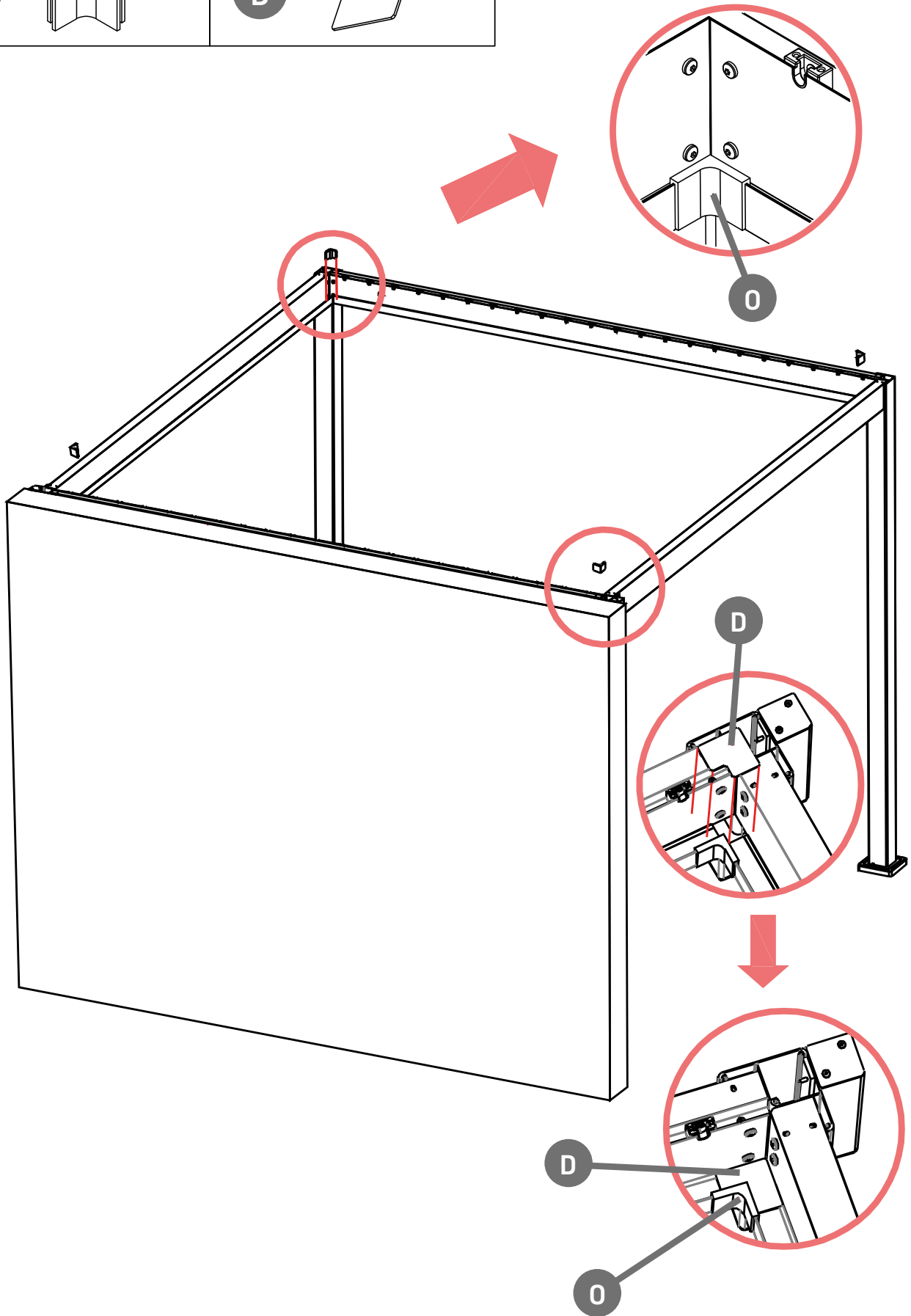
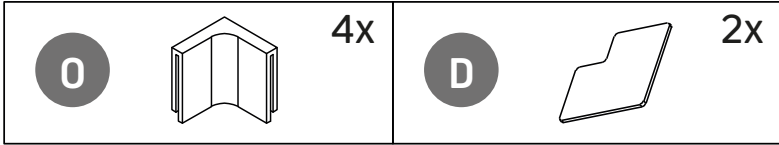

V

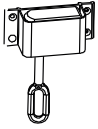

1x

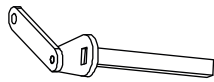

1x



1x



4x

M6X25

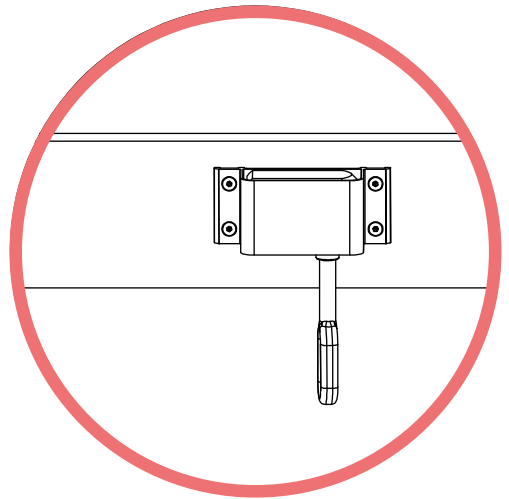
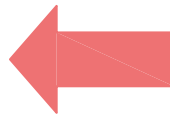
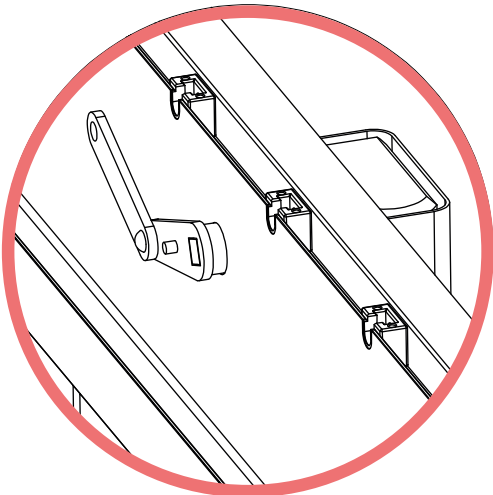
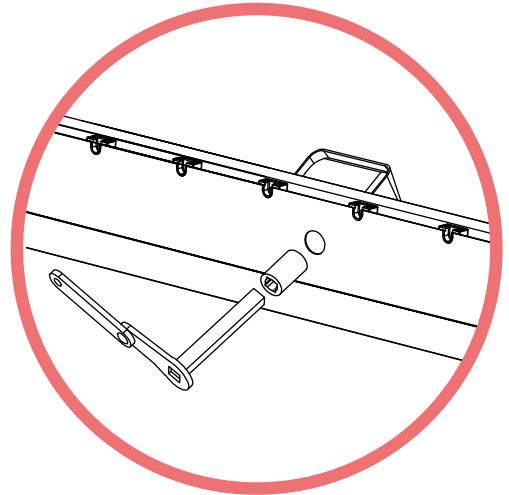
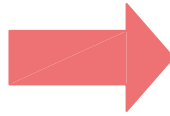
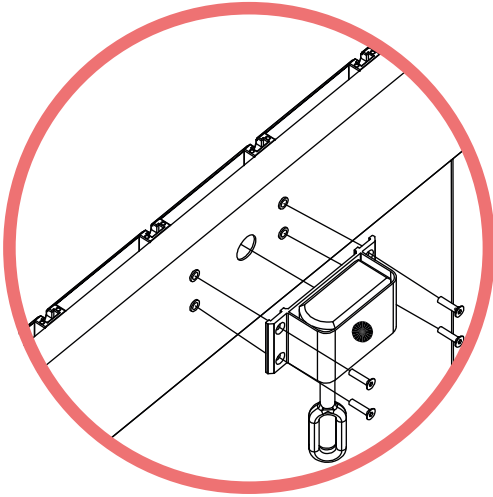

Blade



1x

G

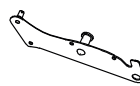

1x



ST4.2X20

3x

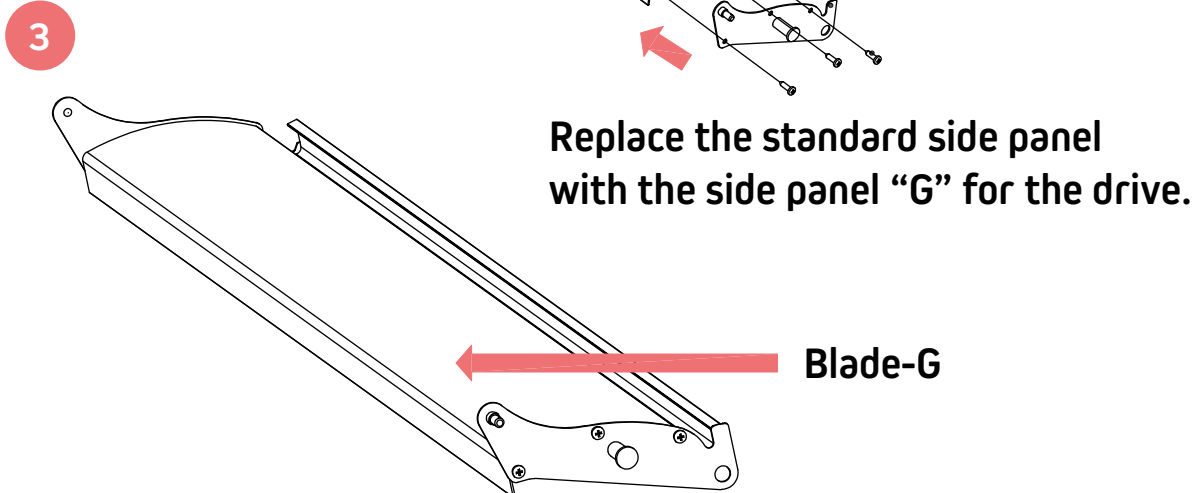
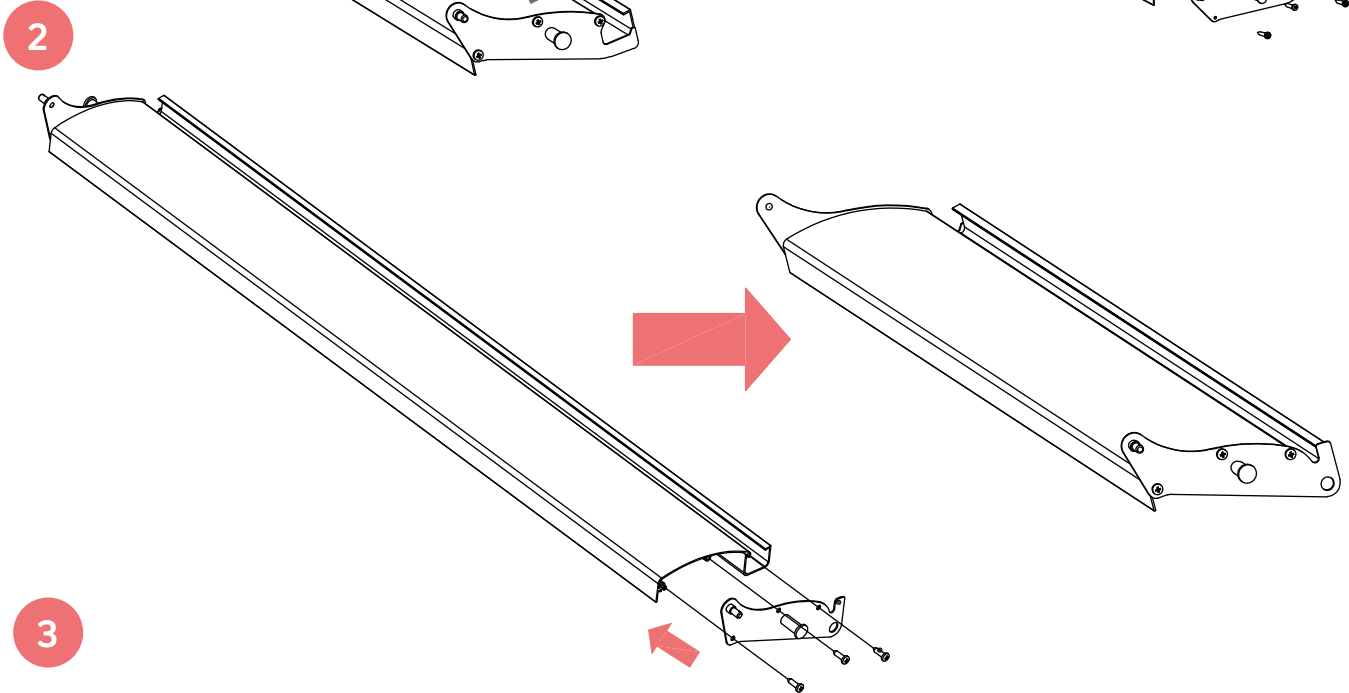
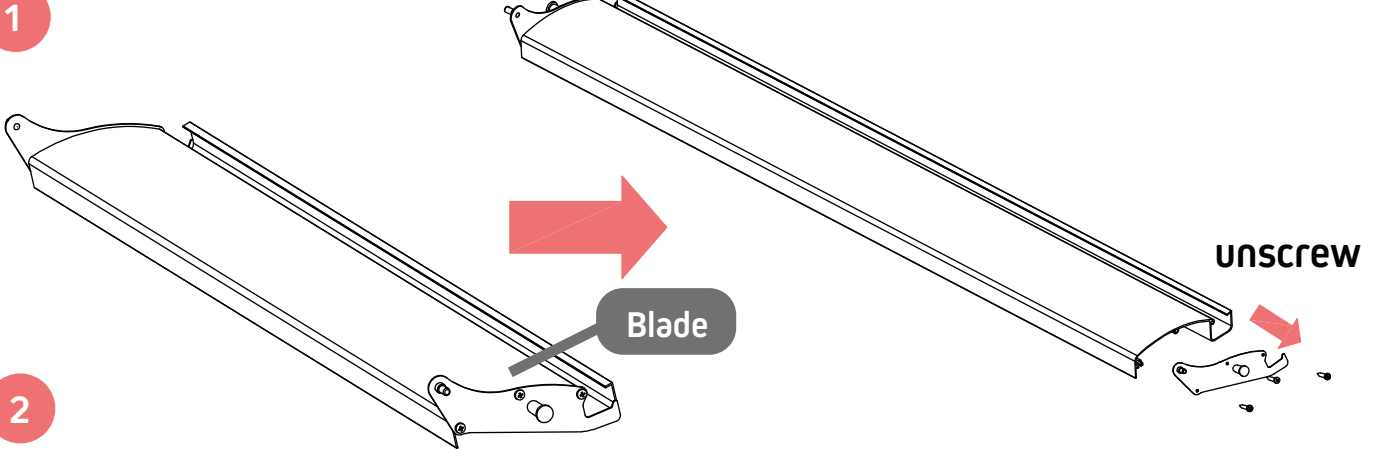

Blades		(3x3m) 20x (3x4m) 28x	Blade-G		1x	G3		1x
---------------	---	--------------------------	----------------	--	----	-----------	---	----

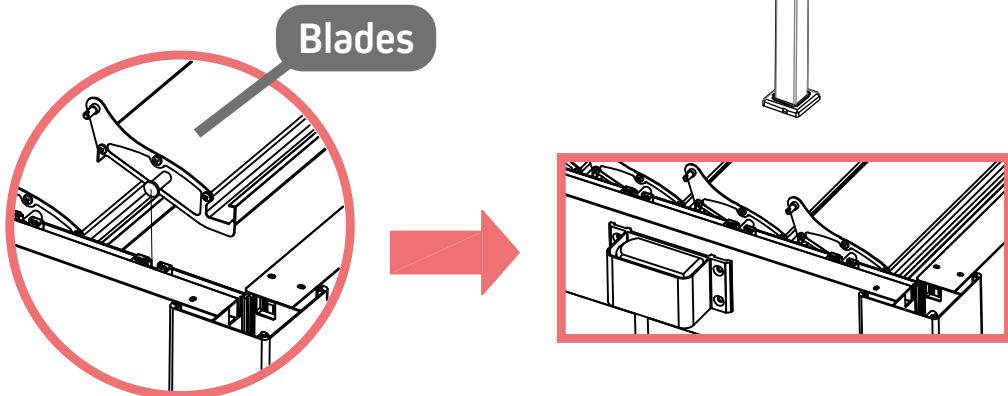
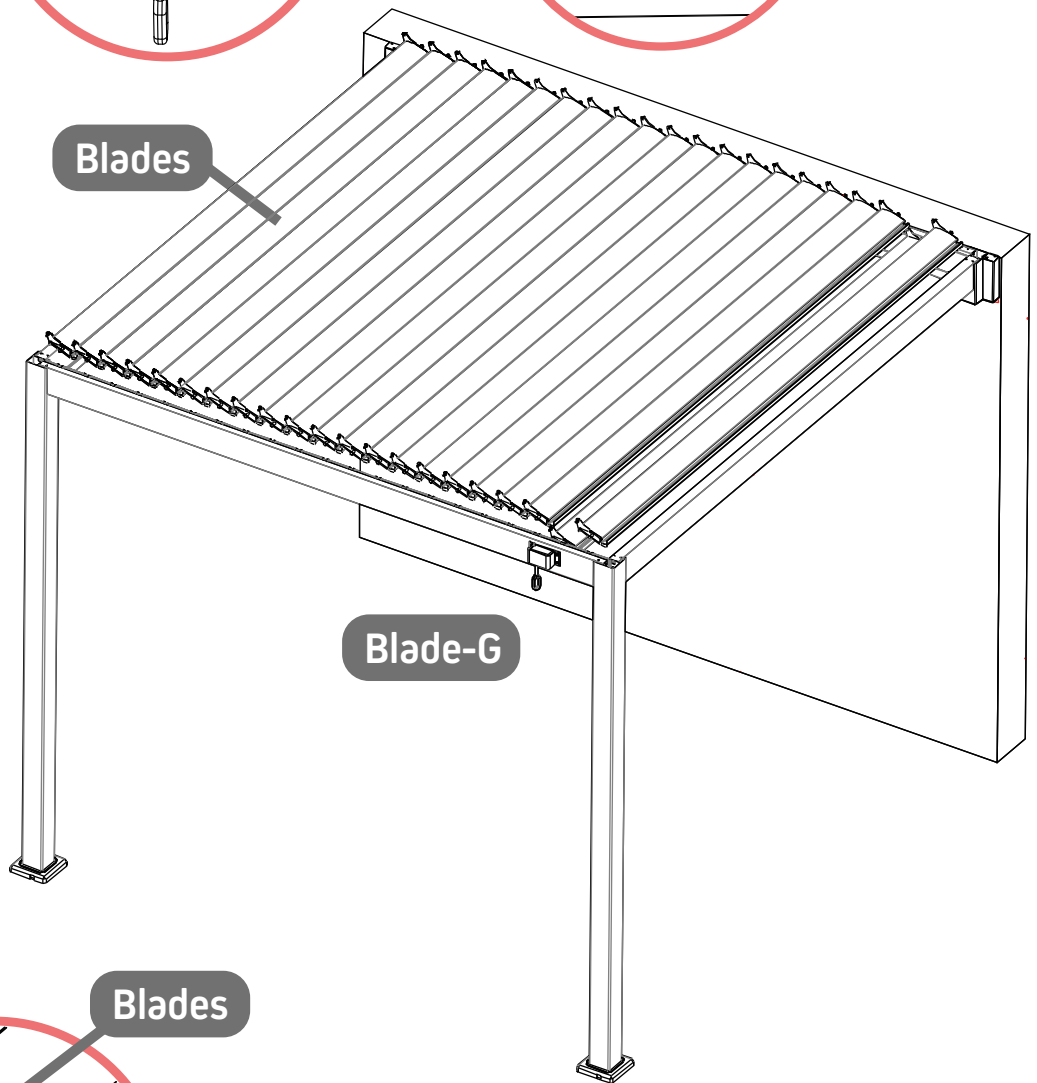
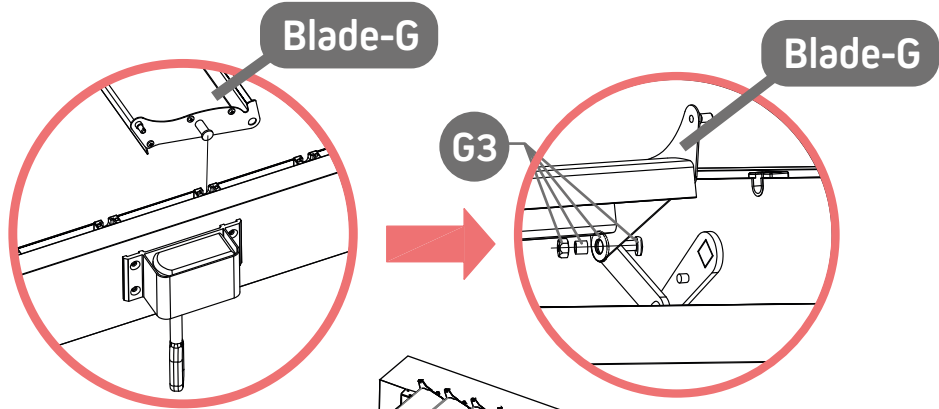

H





(3x3m) 84x
(3x4m) 116x

Beam Cover

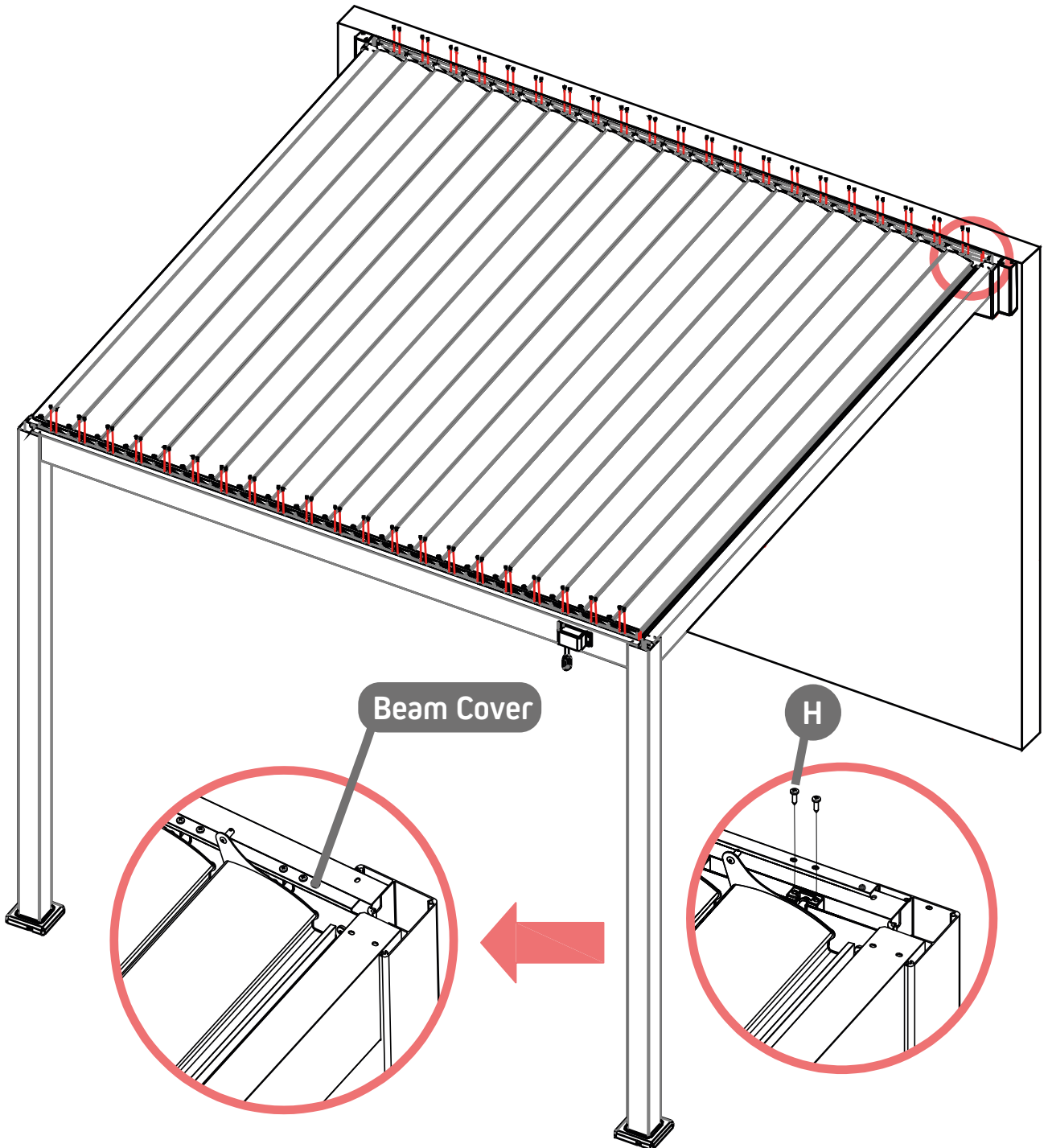
2x



K1		4x	K2	 ST4.2X16	28x
----	---	----	----	---	-----

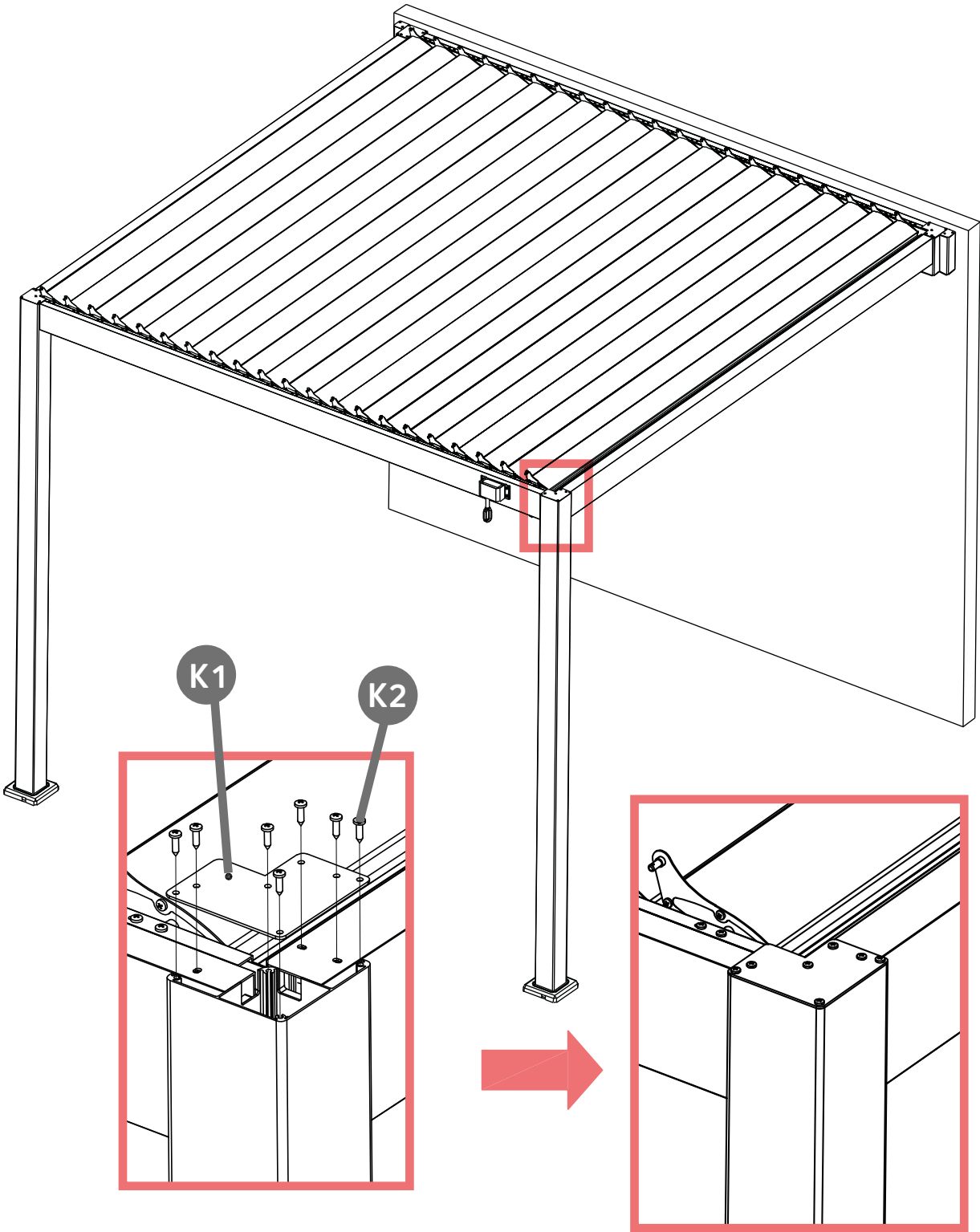

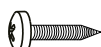
Control Bar	2x	R	 Ø1.5X28	(3x3m) 42x (3x4m) 58x
F	1x	H	 ST4.2X16	6x

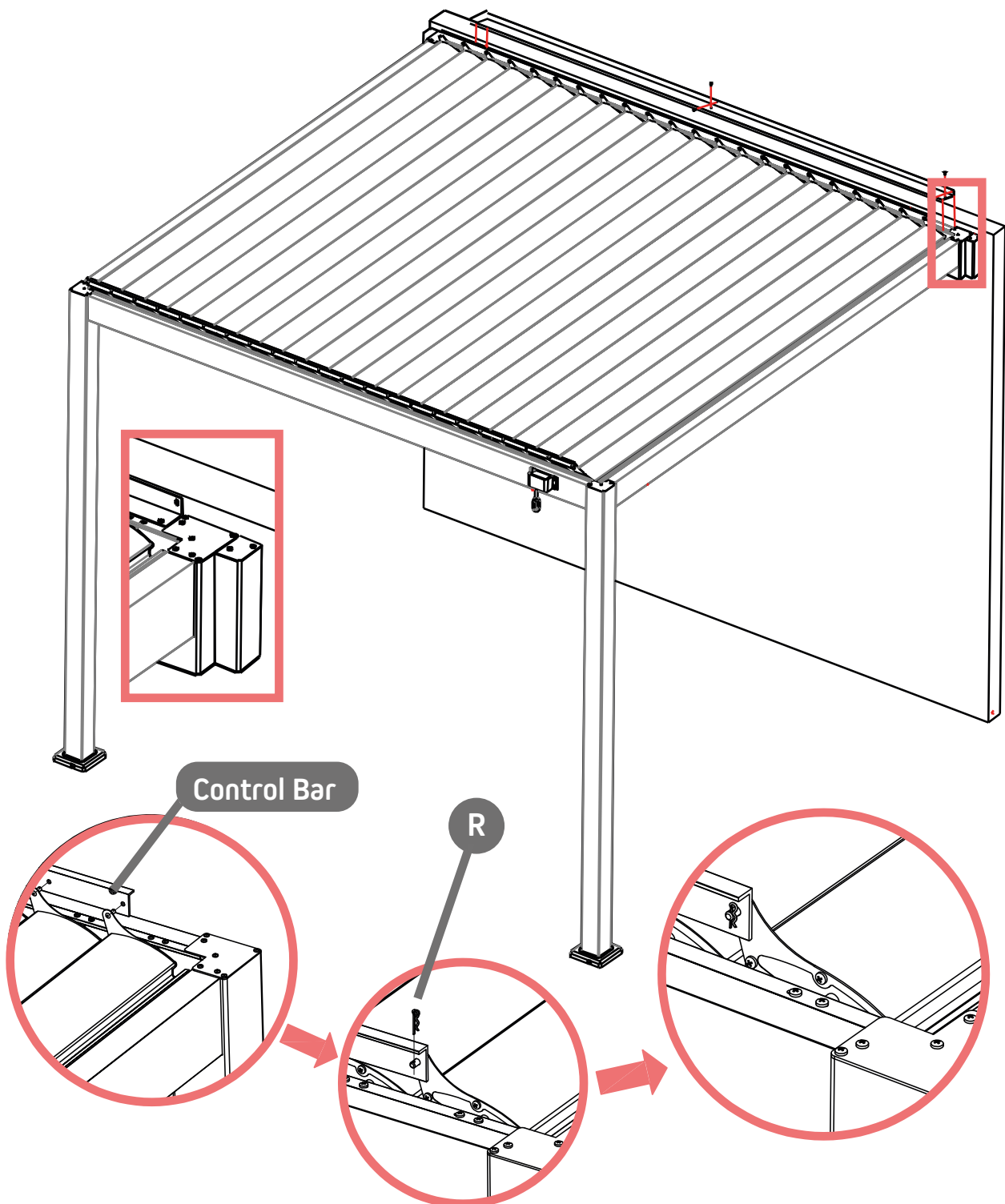

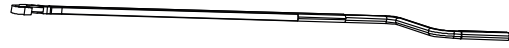
Hand Crank

1x

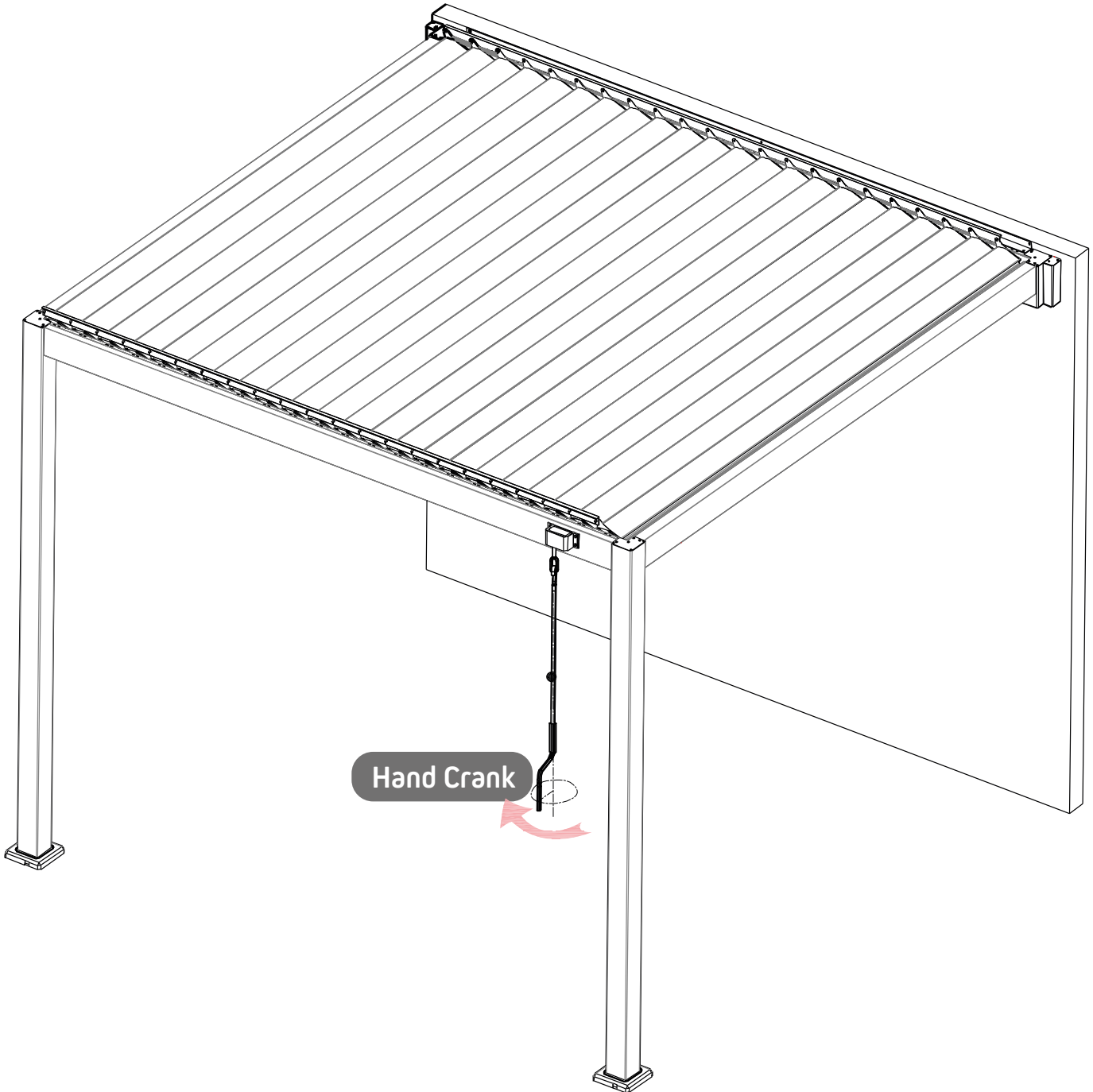

Declaration of performance no.:	dop_sge_ce_pergomondo_20001017_2023_11_v01
Manufacturer / Contact Information:	Schoenberger Germany Enterprises GmbH & Co. KG Zechstr. 1-7 82069 Hohenschäftlarn Tel.: +49 (0) 8178 932 932 info@schoenberger-group.com www.schoenberger-group.com
Brand:	pergomondo
Product type:	Pergola with slatted roof

Unique product type identification code::	2001017*
Year of manufacture from:	11/2023
Intended use:	For outdoor use on its own or on buildings and other structures
Maximum dimensions (Width / Projection):	300 x 400 cm
Wind resistance class:	5
System for evaluation/verification of the constancy of performance of the construction product:	4

The performance of the above product is in conformity with the declared performance.
The manufacturer named above is solely responsible for drawing up the declaration of performance in accordance with Regulation (EU) No.305/2011.
This declaration loses its validity in case of improper use and in case of modifications to the equipment or product that have not been agreed with the manufacturer.

EU Directives:	EU Construction Products Regulation (305/2011 EU)
Applied /harmonised standards:	EN 1090-1:2009 +A1:2011; Execution of Steel Structures and Aluminium Structures - Part 1: Requirements for conformity assessment of structural components

Signed for the manufacturer and
on behalf of the manufacturer by

Michael Mayer
CEO

Hohenschäftlarn
November 2023



*valid for part no. (ID numbers) 1000024803,1000024804, 1000024805, 1000024806, 1000024831, 1000024832, 1000024833, 1000024834, 1000024835, 1000024836, 1000024837, 1000024838.
For a complete list of versions / types, please refer to the original declaration at: <https://www.pergomondo.de/leistungs-konformitaetserklaerungen/>

Document no.:	doc_sge_ce_pergomondo_20001017_2023_11_v01
Manufacturer / Contact Information:	Schoenberger Germany Enterprises GmbH & Co. KG Zechstr. 1-7 82069 Hohenschäftlarn Tel.: +49 (0) 8178 932 932 info@schoenberger-group.com www.schoenberger-group.com
Brand:	pergomondo
Product type:	Pergola with slatted roof

Product type identification code:	2001017*
Year of manufacture from:	11/2023
Intended use:	For outdoor use on its own or on buildings and other structures
Maximum dimensions (Width / Projection):	300 x 400 cm
Wind resistance class:	5

We, Schoenberger Germany Enterprises GmbH & Co. KG, declare that the above-mentioned product in its design and in the version placed on the market by us complies with the relevant essential performance and safety requirements, prescribed by the EU directives stated below.
This declaration loses its validity if the use does not correspond to the intended purpose and in the event of changes to the system or product that have not been agreed with the manufacturer.

EU Directives:	Machinery Directive 2006/42/EG
Applied /harmonised standards:	EN 1090-1:2009 +A1:2011; Execution of Steel Structures and Aluminium Structures - Part 1: Requirements for conformity assessment of structural components

Signed for the manufacturer and
on behalf of the manufacturer by

Michael Mayer
CEO

Hohenschäftlarn
November 2023



*valid for part no. (ID numbers) 1000024803,1000024804, 1000024805, 1000024806, 1000024831, 1000024832, 1000024833, 1000024834, 1000024835, 1000024836, 1000024837, 1000024838.

For a complete list of versions / types, please refer to the original declaration at: <https://www.pergomondo.de/leistungs-konformitaetserklaerungen/>

EU Waste and recycling / Registrations

Germany for electrical devices:

Stiftung EAR

WEEE-Reg.-no.: DE 41060608

Germany for batteries:

Stiftung EAR

Batt-Reg.-no.: DE 88866710

Germany for packaging:

LUCID Reg.-no.: DE5768543732165

Austria for electrical devices:

Elektro Recycling Austria (ERA) GmbH

ERA Contract no: 40801

Austria for packaging:

Altstoff Recycling Austria (ARA) AG

ARA License number: 23363

Switzerland for electrical devices:

Stiftung SENS

Membership number: VP11544

France for electrical devices:

Ecologic

Membership number / Take-back system: M3670

National registry: UIN FR208795_01SUIN

France for packaging:

Citeo

Membership number / Take-back system: 532886

National registry: UIN FR208795_01SUIN

Spain for electrical devices:

ECOTIC

Reg.-no.: RII-AEE- 7601

Spain for packaging:

Ecoembes

Membership number: 97556

Italy for electrical devices:

Raccolta differenziata. Verifica le disposizioni del tuo Comune!

Reg.-no.: xxx

Italy for packaging:

Raccolta differenziata. Verifica le disposizioni del tuo Comune!

Membership number: xxx

pergomondo

ist eine eingetragene Marke der / is a registered trademark of
Schoenberger Germany Enterprises GmbH & Co. KG
Zechstraße 1-7, 82069 Hohenschäftlarn

Tel.: 08178 / 932 932

Fax: 08178 / 932 970 20

info@pergomondo.de

www.pergomondo.de

Nachdruck, auch auszugsweise, nur mit Genehmigung des Verfassers.

Produktveränderungen, die aus unserer Sicht einer Qualitätsverbesserung dienen, können jederzeit, auch ohne Vorankündigung oder Mitteilung, durchgeführt werden.

Abbildungen können Beispielabbildungen sein, die im Erscheinungsbild von der gelieferten Ware abweichen.

Irrtümer vorbehalten. Für Druckfehler wird keine Haftung übernommen. Es gelten unsere allgemeinen Geschäftsbedingungen.

Reprinting, even in extracts, only with permission of the author.

Product changes that serve to improve quality from our point of view can be made at any time, even without prior notice or notification.

Illustrations can be examples that deviate in appearance from the delivered goods.

Errors excepted. No liability is assumed for printing errors.

Our general terms and conditions apply.